

Super Panel

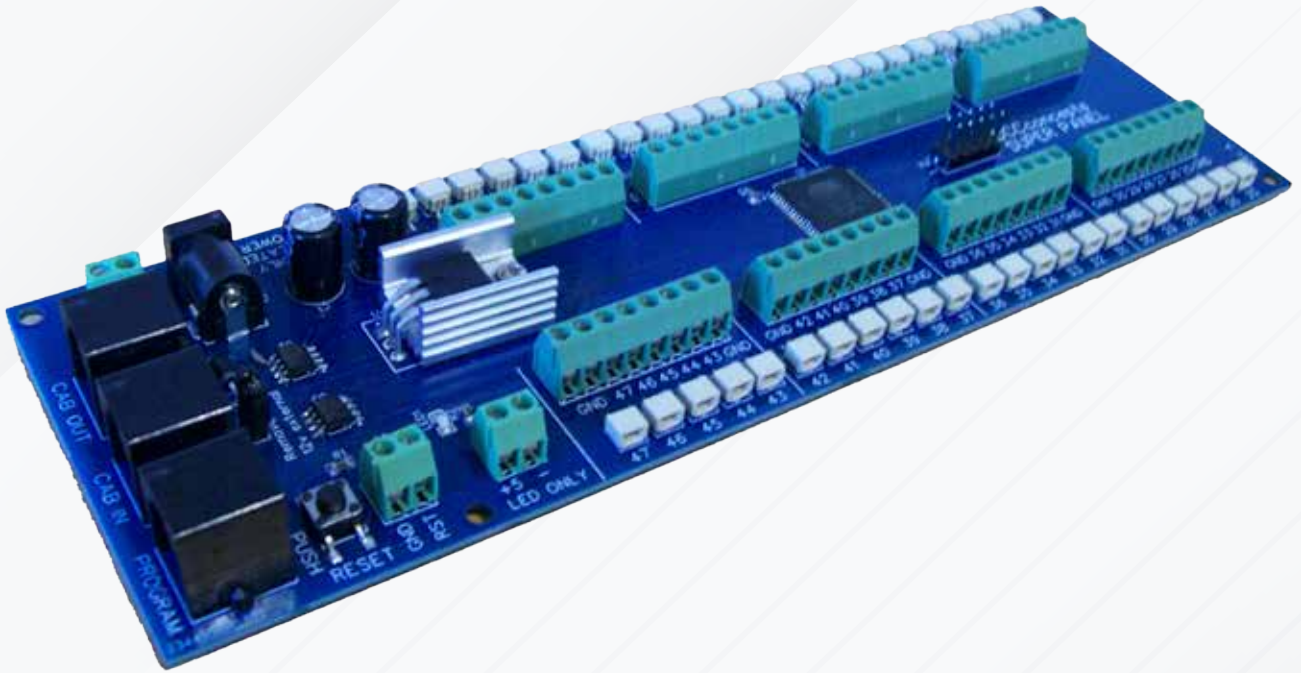

Quick User Guide

**A quick guide to setting up and using your
Layout Concept Super Panel**

Version 1.2

L A Y O U T

C O N C E P T S

Super Panel

1 - Welcome

Thank you for purchasing the Layout Concepts Super Panel.

This device will allow you to supercharge the control of your model railway. You will be able to control DCC accessories, signals, point motors, locomotives, relays - in fact the list is pretty endless.

This is a quick guide to showing you what is in the box, the connection on the Super Panel, how to connect up the Super Panel to start programming, enter a simple program, and controlling your first accessory.

At the end of this Quick User Guide there will be a link to download the full user guide.

2 - You Will Need

The Layout Concepts Super Panel has been designed to be used with the one of the following NCE DCC Systems:

NCE Power Cab:



NCE Power Pro:



The Super Panel will not work with any other DCC system, please do not connected it up, as you may damage the Super Panel or your DCC control system.

3 - In The Box

When you open the packaging, you should find the following components in the box:

1 x Quick User Guide



1 x Layout Concepts Super Panel

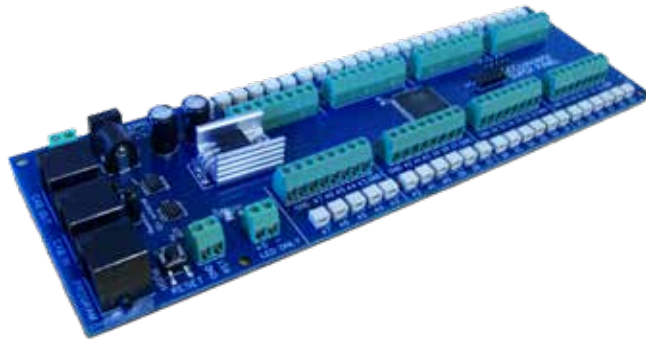

1 x RJ12 Flat Programming Cable - 1.7metres



12 x Connection Cables - 500mm



4 - Super Panel Connections

The diagram below shows all the connection on the Super Panel board. Depending on what you are connecting to the Super Panel will determine which connections you use.

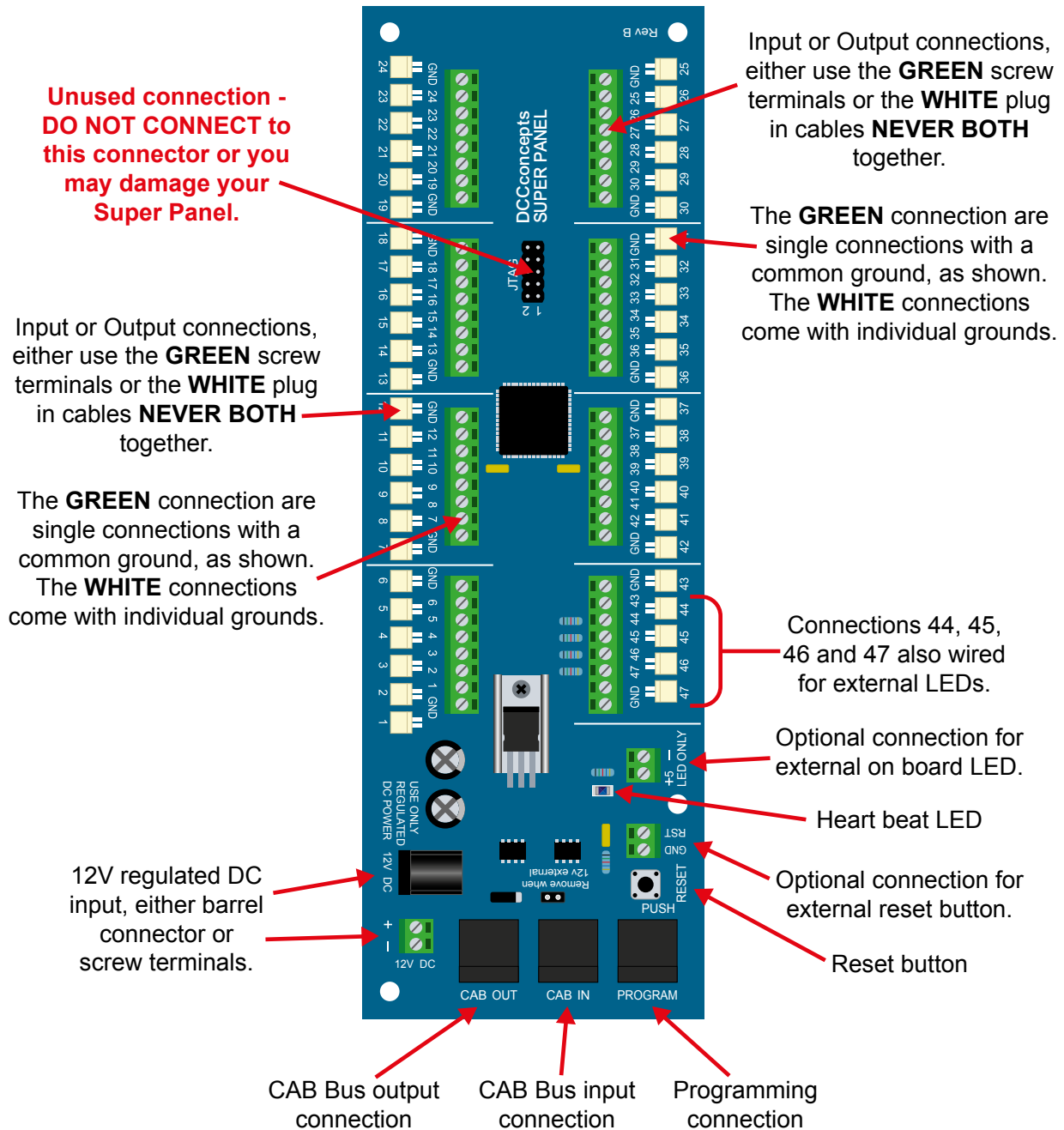

Layout Concepts use the 2 pin JST sockets extensively on its products. These are usually used to connecting Mimic LEDs to a device/circuit board.

Please note, apart from connections 44, 45, 46 and 47, DO NOT DIRECTLY CONNECT ANY LEDs, Mimic or 3rd party, to the Super Panel on ANY OTHER connections, either using the screw terminals or the white sockets. If you do, you may damage the Super Panel.

The green screw terminals and white sockets are wired in parallel so they can **ONLY** be used as a dedicated **INPUT** or **OUTPUT** but **NOT** both at the same time.

5 - Input/Output Connections

The diagrams below show the two different ways you can connect a device to the Super Panel board. Depending on what you are connecting will determine which connections you use.

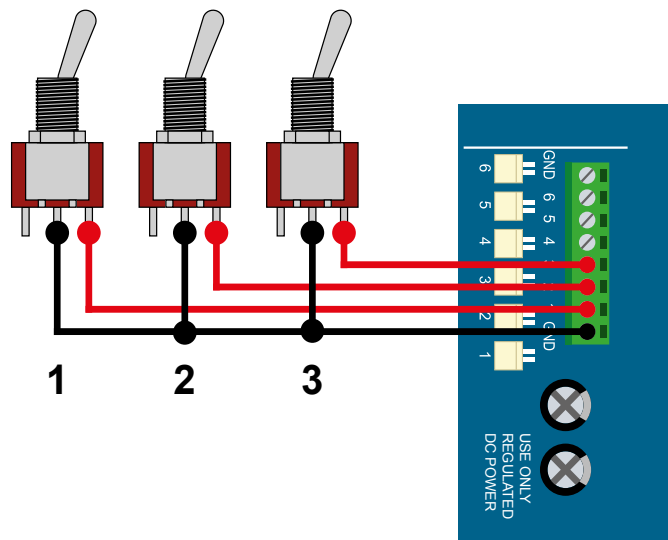

When connecting a device to the Super Panel, if you use the **GREEN** screw terminals, the Super Panel has a set of **COMMON GROUND** connections throughout the board.

You do not need to use the **GROUND** connection that is on the same green block. All the 47 input/output connectors have common grounds when using the **GREEN** screw terminals.

The **SIGNAL** part is a single screw connection to the relevant terminal.

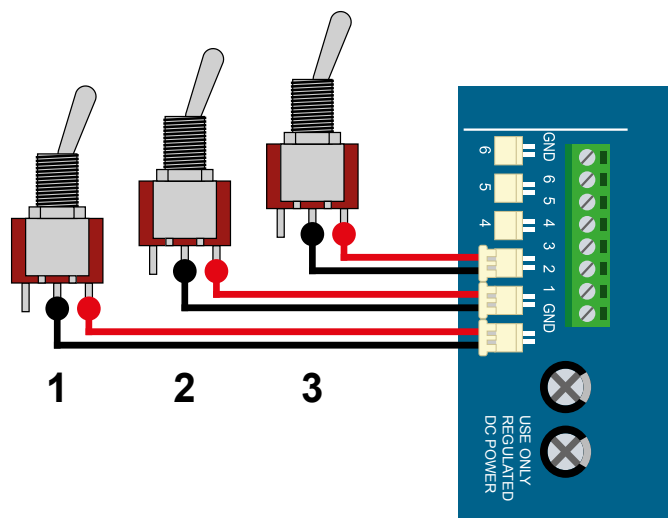

If you are using the supplied **RED** and **BLACK** 2 pin cables with the JST connection, the **SIGNAL** and **GROUND** are included in the same connector block.

You do not need to connect a separate **GROUND** to the **GREEN** screw terminals on the Super Panel.

You can use a mixture of both the WHITE JST connectors and the GREEN screw terminals when connecting devices to the Super Panel.

6 - Connecting Everything Up

NCE Power Pro

The diagram shows how to connect an NCE Power Pro to the Super Panel using a Layout Concepts 18V Regulated DC Power Supply to power the NCE Power Pro. Please note, all the cable used **MUST BE** the 6-core type, like the Layout Concepts DCD-ACL.

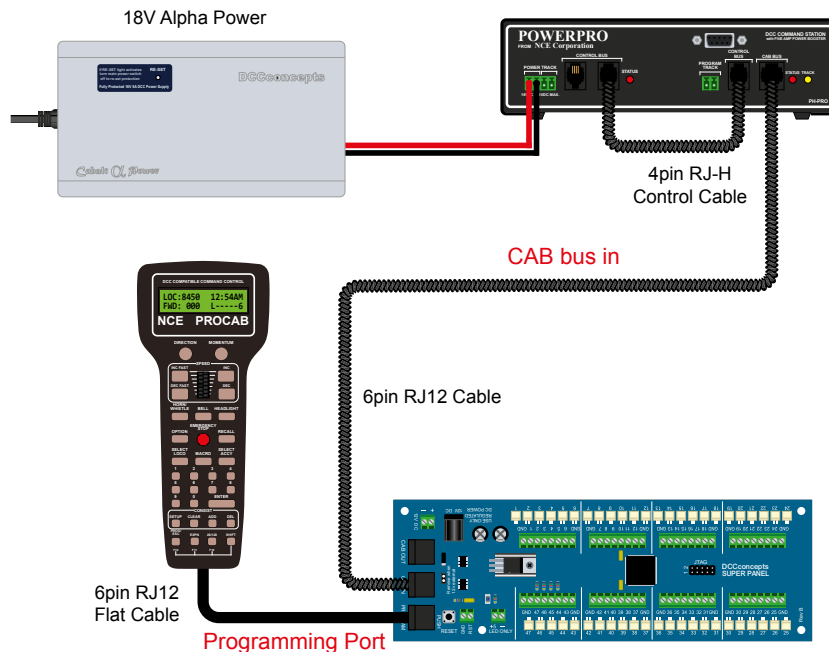

NCE Power Cab

The diagram shows how to connect an NCE Power Cab to the Super Panel, using the NCE PCP faceplate. Please note, all the cable used **MUST BE** the 6-core type, like the Layout Concepts DCD-ACL.

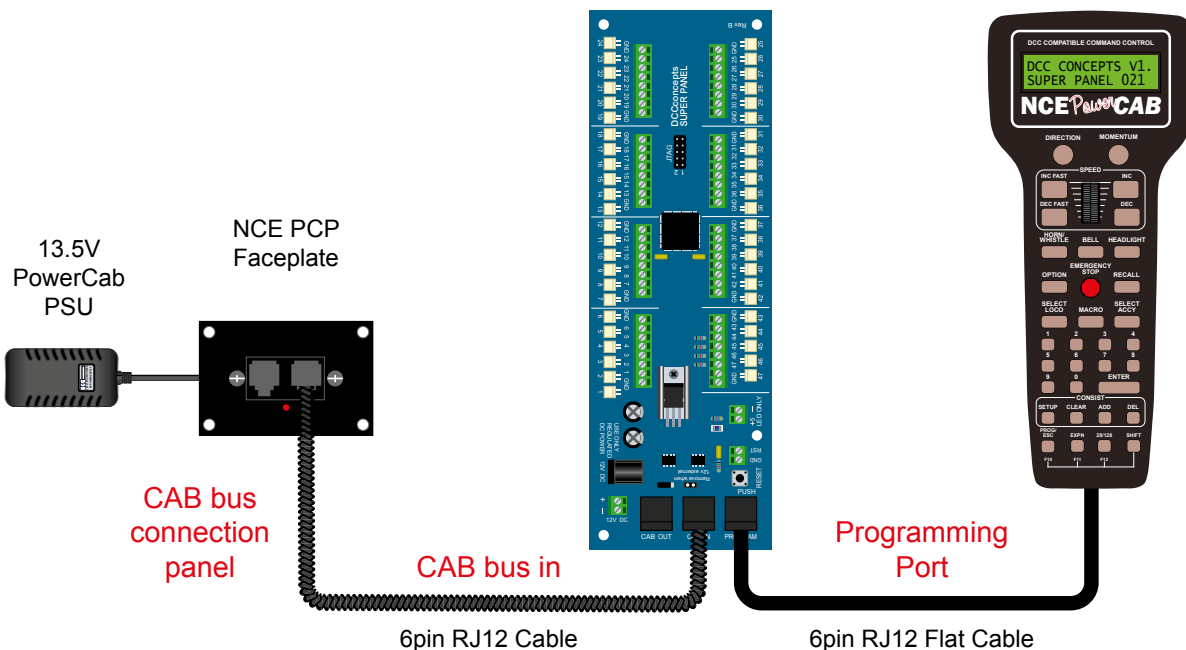

The Super Panel can be programmed whilst connected to your CAB bus. Depending on what you are programming we suggest removing the CAB OUT connector whilst performing this task.

6 - Controlling A Single Digital Point Motor

Here is a quick guide to controlling a single point motor using an ON-OFF toggle switch. We are using an NCE PowerCab but the process is exactly the same if you use an NCE Power Pro - see the connection guide on the previous page.

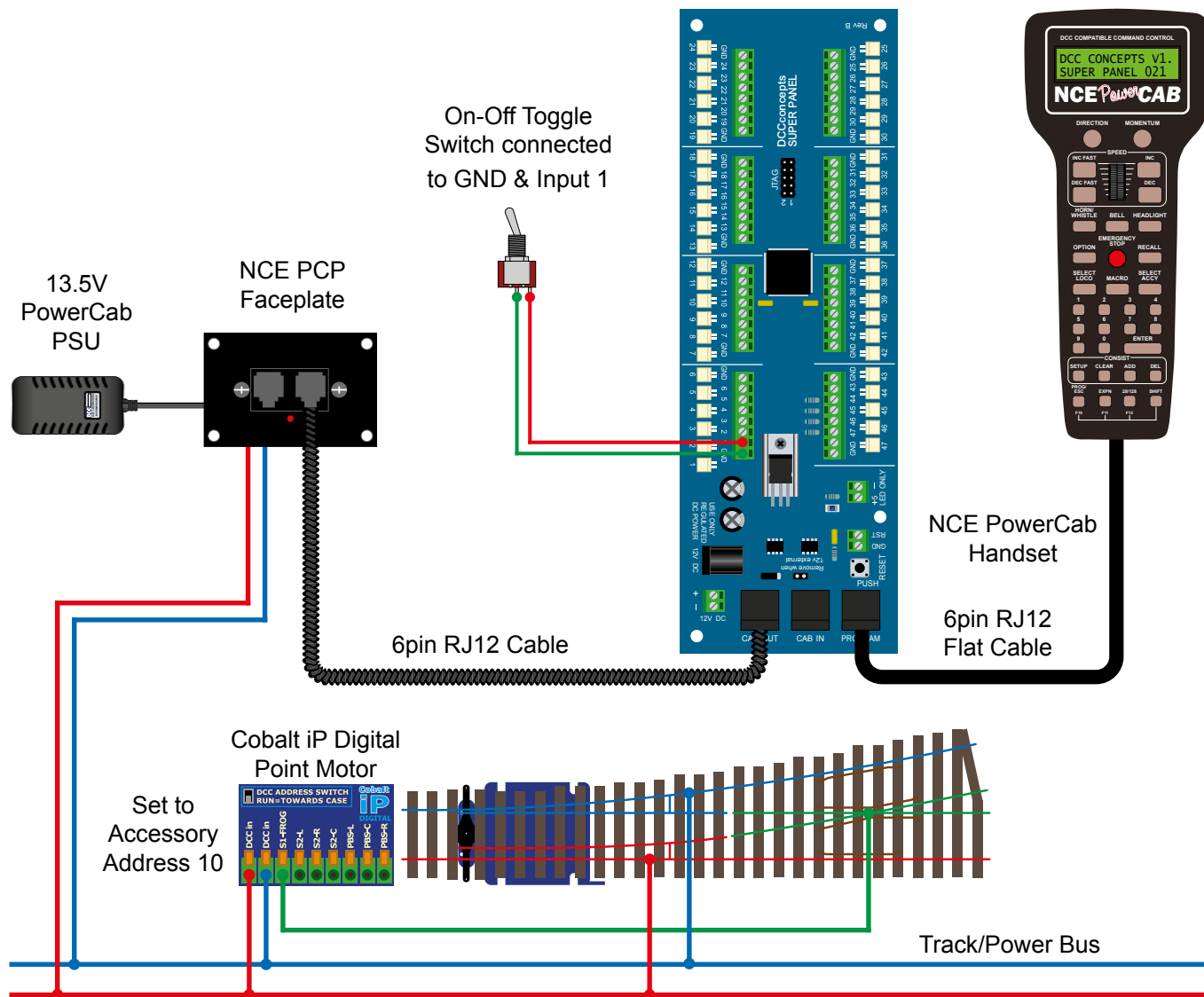

The **ON-OFF** toggle switch is connected with the centre common to one of the Super Panel ground connections, and the switched connection to Input 1 on the Super Panel.

The Cobalt iP Digital point motor is connected to the normal track/power bus from the NCE Power Pro base unit, and has been assigned digital accessory address 10.

Step 1

Connect everything as per the above diagram and the **START SCREEN** will appear, press **ENTER** to move to the **Main Menu**:

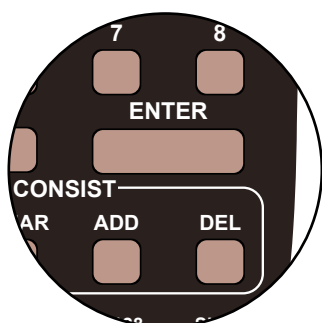

Start Screen

DCC CONCEPTS V1.
SUPER PANEL 025B

Press

ENTER

1=SETUP 2=REVIEW
3=TEST OPERATION

Step 2

Select **1=SETUP** by pressing **1**, and then **1=SET INPUT** by pressing **1**:

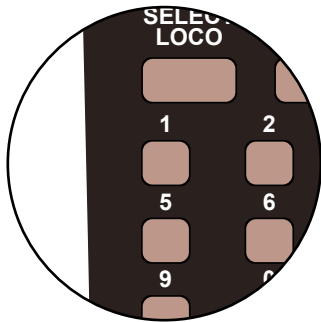

Press

1

THEN

Press

1

```
1=SETUP INPUT
2=SETUP CONFIG
```

```
SETUP INPUT MENU
INPUT:1 LO/HI:L
```

Step 3

First we set what the switch will do when it is **LOW** or **ON**, so leave the **LO/HI** at **L**. Next select **INPUT:1**, the Super Panel input you have connected the switched terminal from the toggle switch to, by pressing **1** and **ENTER**, and then select **STEP:1** by pressing **ENTER**:

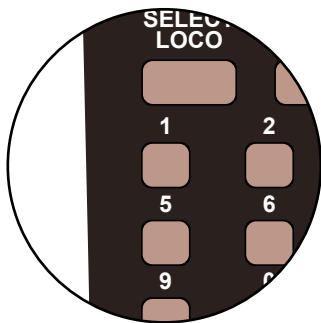

Press

1

THEN

ENTER

THEN

ENTER

```
INPUT:11 LOW
STEP: 1
```

```
INP:11 L STEP:1
1=ACCY 2=MACRO >
```

Step 4

We have to tell the Super Panel what the device we are controlling from **INPUT 1** is. The point motor is an accessory so press **1**, then confirm the accessory number, **10**, of the motor by pressing **1** then **0** and **ENTER**.

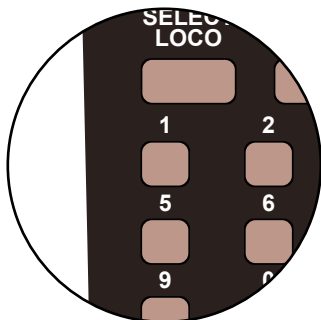

Press

1

Then Press

1

Then Press

0

Then Press

ENTER

```
INP:1 L STEP:1
ACCY NUMBER:10
```

```
INP:11 L STEP:1
NORM/REV : N/1
```

Step 5

We next program the direction of the point motor, either **N/1** - straight or **R/2** - switched. This is done by using the **DIRECTION** key. We want **N/1**, so leave the settings as show on the screen and then **ENTER** to finish these settings. Push the **PROG/ESC** key 2 times to return to the **SET INPUT MENU SCREEN**



Press

DIRECTION

THEN

Press

ENTER

```
INP:11 L STEP:1
NORM/REV : N/1
```

```
INP:11 L STEP:2
1=ACCY 2=MACRO >
```

Step 6

Next we need to tell the Super Panel what to do when the **ON-OFF** toggle switched is switched **OFF**, in essence, moving the point switch the other way. So from the **SETUP INPUT MENU SCREEN**, push the **DIRECTION** key to change Input 1 to look at the **HIGH/OFF** command, and press **ENTER**.

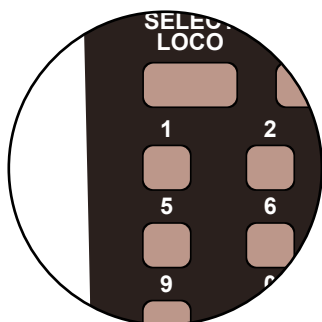

Press
DIRECTION
THEN
Press
ENTER

```
SETUP INPUT MENU
INPUT:1 LO/HI:H
```

```
INPUT:1 HIGH
STEP: 1
```

Step 7

As before we are controlling accessory number **10** from **INPUT 1**, so select **STEP 1** and press **ENTER**. Select accessory by pressing **1** and enter accessory number **10** by pressing **1** then **0**, and then press **ENTER**

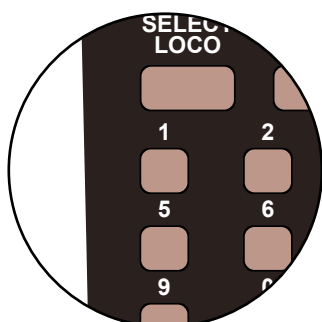

Press
1
Then Press
1
Then Press
0
Then Press
ENTER

```
INP:1 H STEP:1
1=ACCY 2=MACRO >
```

```
INP:1 H STEP:1
ACCY NUMBER:10
```

```
INP:1 H STEP:1
NORM/REV : N/1
```

Step 8

This time we want the motor to move the opposite direction than before, so we want **REVERSED/2**. Press the **DIRECTION** key to select **R/2** and then **ENTER** to finish these settings. Push the **PROG/ESC** key 4 times to return to the **SET UP MENU SCREEN**



Press
DIRECTION
THEN
Press
ENTER

```
INP:1 H STEP:1
NORM/REV : R/2
```

```
INP:1 H STEP:2
1=ACCY 2=MACRO >
```

Push the **PROG/ESC** key 4 times to return to the **SET UP MENU SCREEN**

You have now setup your first switch to an input to control a digital accessory on the Super Panel.

There are so many more items you can control with your Layout Concepts Super Panel, for example control the functions on locomotives, change locomotives CV's, control signals and use block detection, to name but a few!

Over the coming months we will release small programming guides to show you in much more detail some of the programming for the Super Panel for specific operations. The first of these on Point Motor Control will be available in the coming weeks.

In the meantime, either scan the QR Code to download the full Super Panel User Guide, and see what it can really do!

Don't forget we are here to help you, just drop us an email or pick up the phone.

The Layout Concepts Super Panel is a complex piece of equipment but if you follow the instructions you will have a exquisite control panel in no time. Should you feel that this is too much, we offer a design and programming service to help you configure your Super Panel. Please contact Sales for more information regarding this.

Disclaimer

The material in this manual is for informational purposes only. The products it describes are subject to change without prior notice, due to the manufacturer's continuous development program.

Layout Concepts makes no representations or warranties with respect to this manual or with respect to the products described herein.

Layout Concepts shall not be liable for any damages, losses, costs or expenses, direct, indirect or incidental, consequential or special, arising out of, or related to the use of this material or the products described herein.