

# LAYOUT

## CONCEPTS

### Alpha Switch-i Controlling A Crossover With Cobalt iP Digital & Alpha Mimic & ESP Transmitter & Receiver Boards

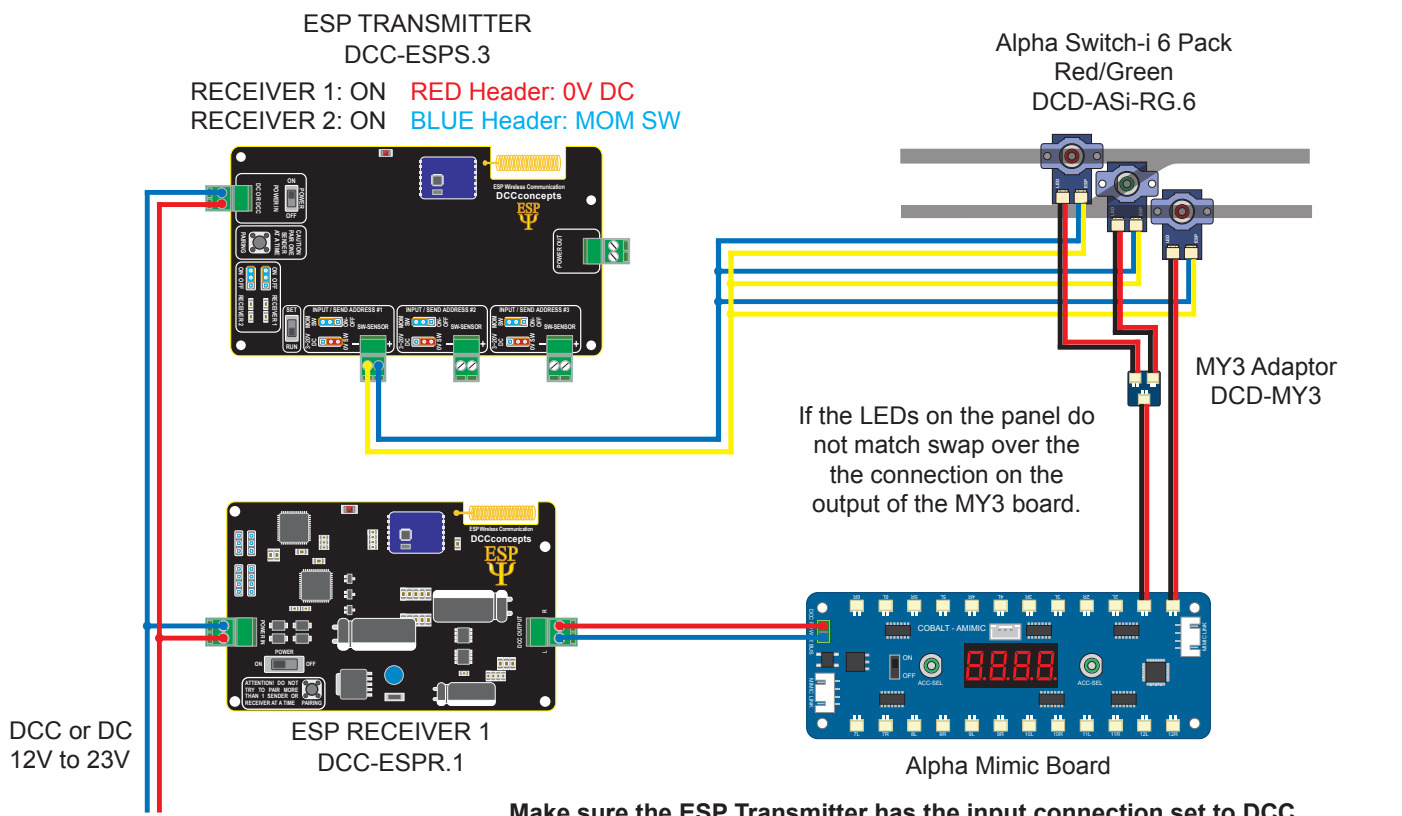

Make sure the ESP Transmitter has the input connection set to DCC Accessory Address 1 to match the pair of point motors it is controlling.

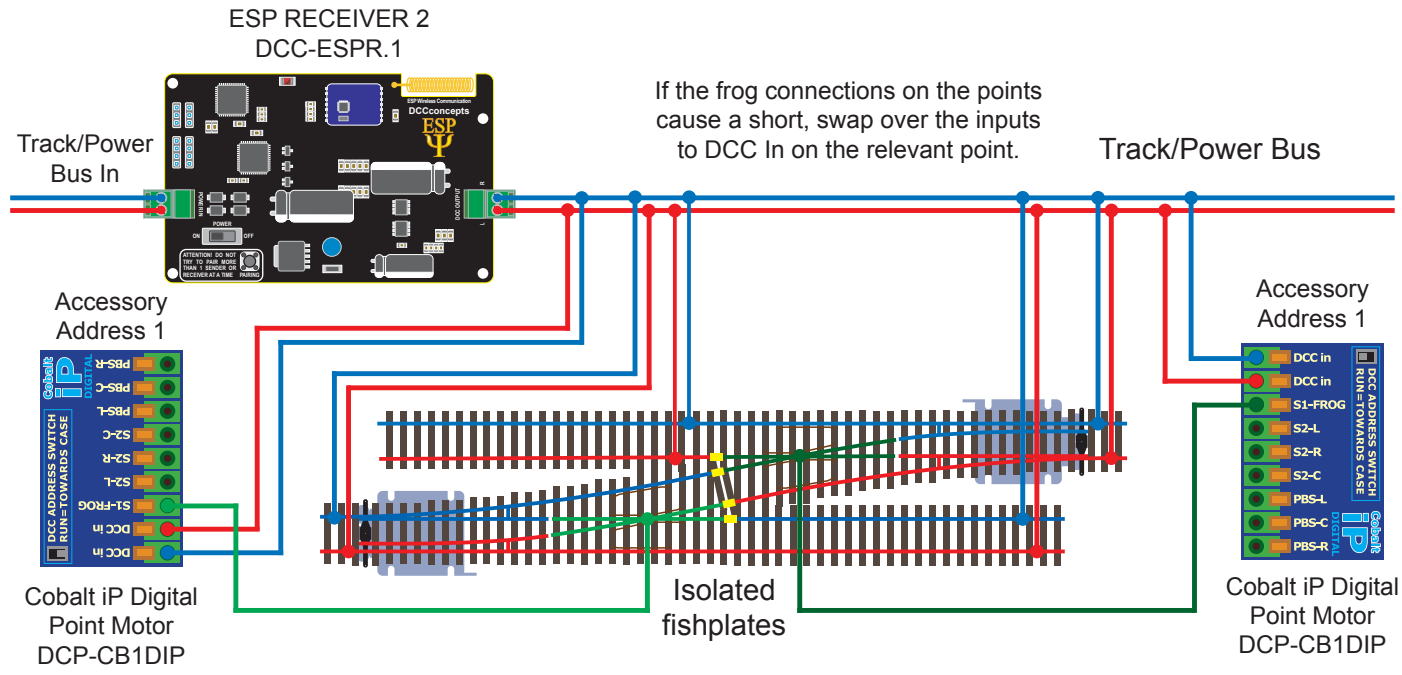

If the frog connections on the points cause a short, swap over the inputs to DCC In on the relevant point.