

LAYOUT

CONCEPTS

ESP Transmitter Board Using Cobalt S-Levers

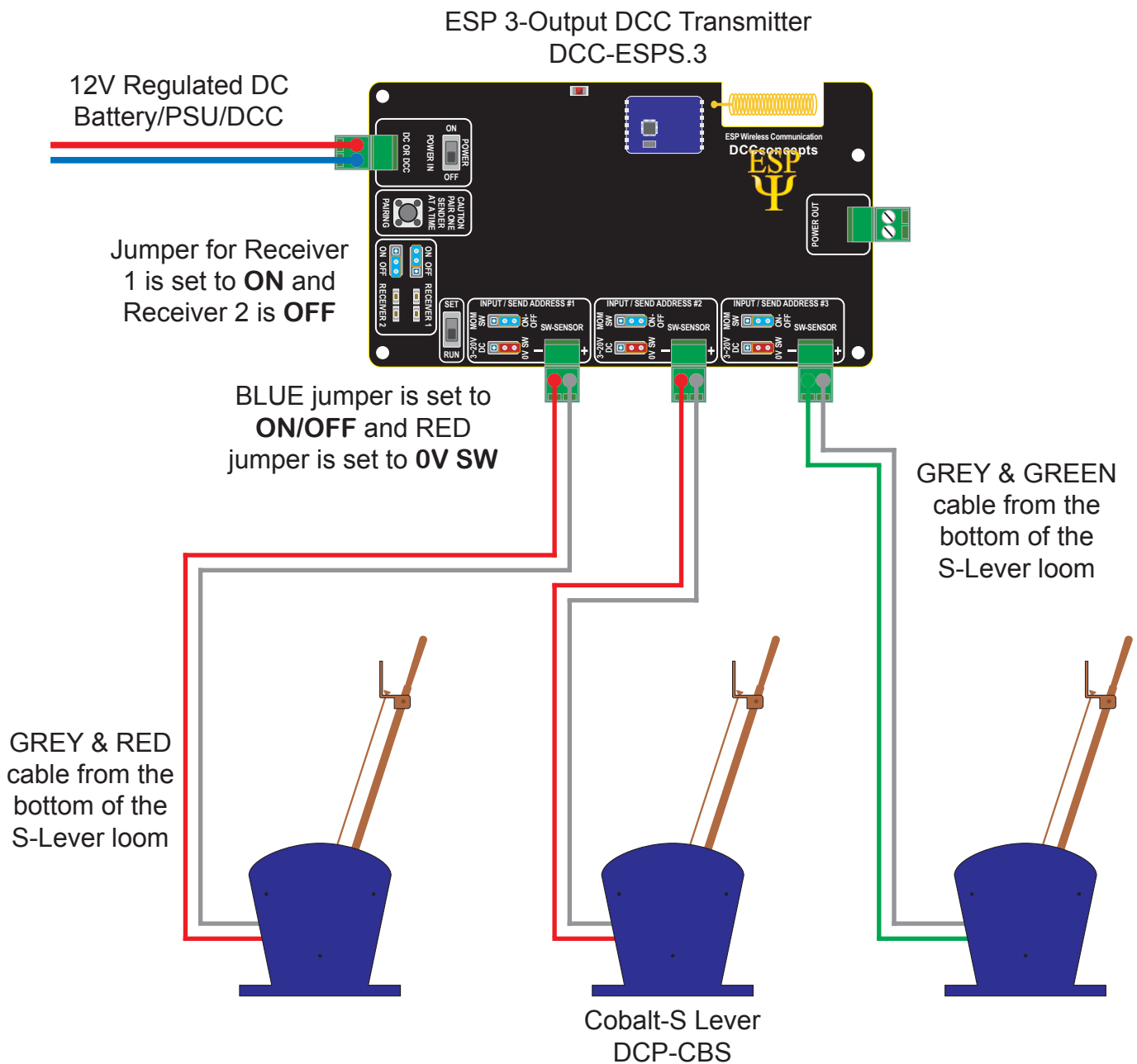

Use either the RED and GREY wires or GREEN and GREY wires from the bottom of the S-Lever wiring harness, depending on which way you want the S-Lever to operate.

