

LAYOUT

CONCEPTS

Cobalt iP Digital Point Motor Control Of An ABC Module

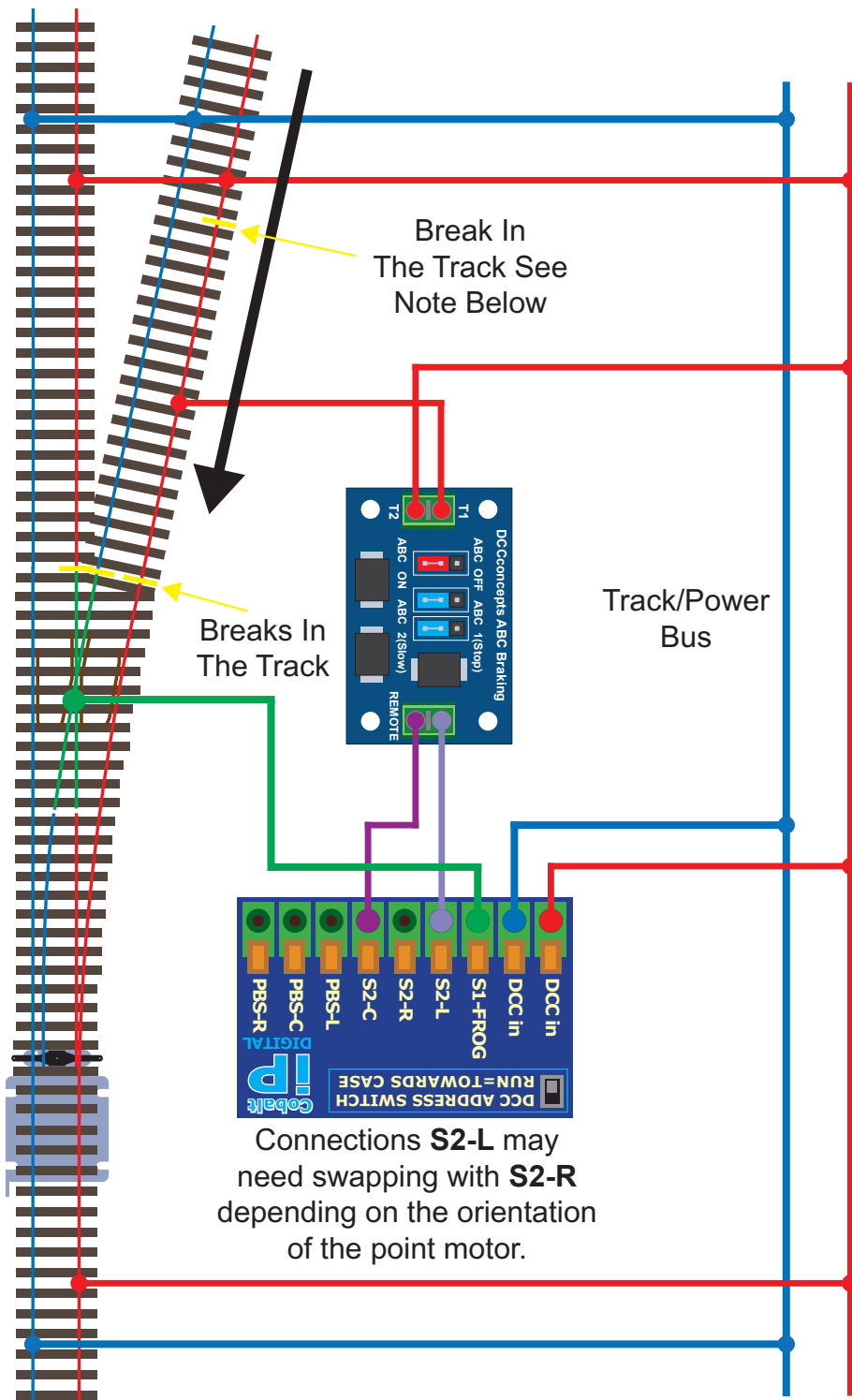

The large black arrow shows the direction of travel towards the point. If the point is against the siding, the train will stop. The train will then move off when the point is thrown the correct way.

You will need to change CV27 to 3 to activate the ABC on the decoder and you may also need to adjust deceleration CVs, ie CV4 etc.

The track break on the siding may need to be moved further to the left to allow the train time to stop before the junction.