

Super Panel Sample Set-Ups

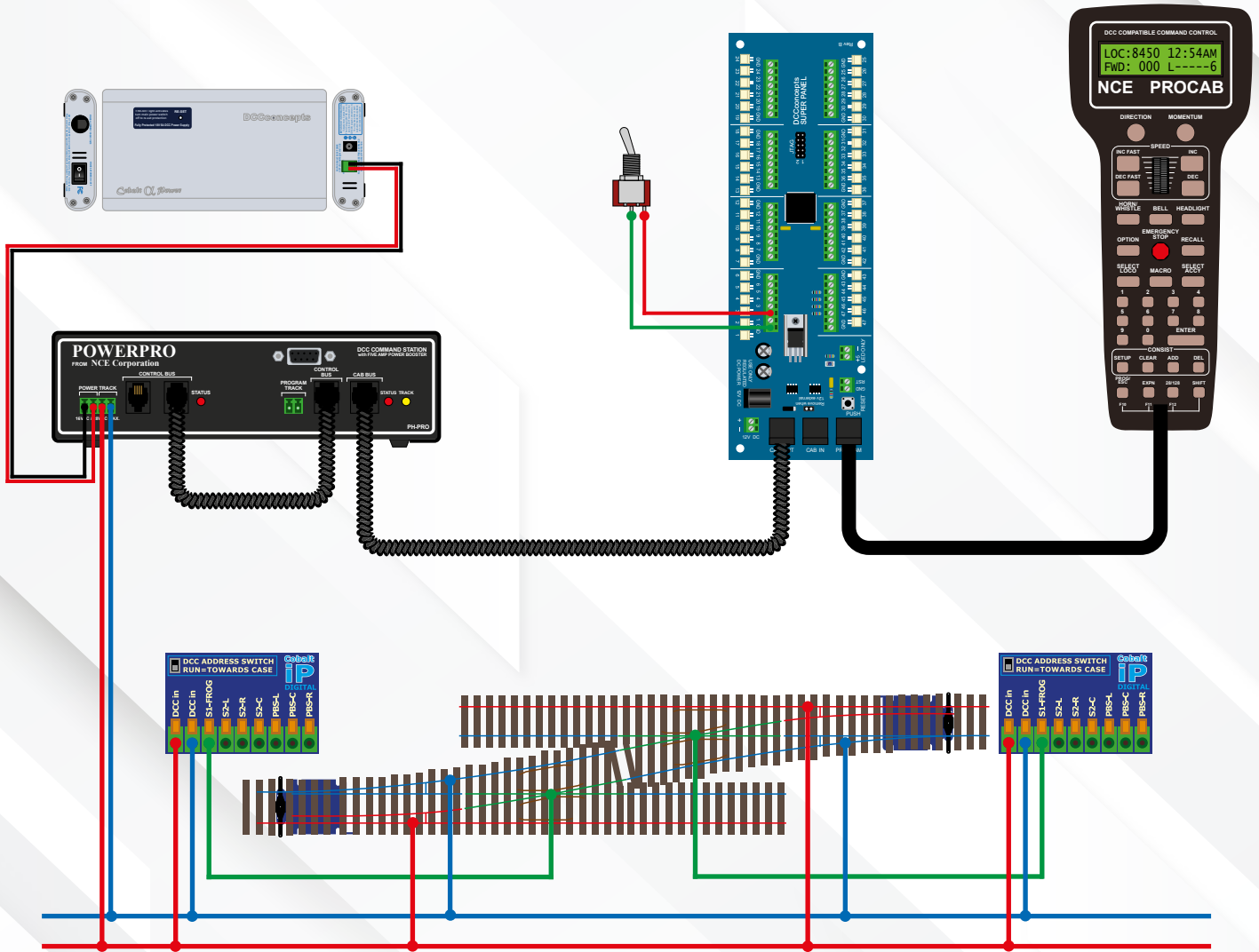

Volume One - Point Motor Control

L A Y O U T

C O N C E P T S

Contents

Single Point Control Using One On-Off Toggle Switch	5
Dual Point Control Using One On-Off Toggle Switch	12
Controlling Two Separate Points Using Two On-Off Toggle Switches	16
Controlling A 3-Way Point Using Three Push To Make Switches	24
Connecting a Cobalt S-Lever To Super Panel	35
Connecting Alpha Switch-i To Super Panel & Alpha Mimic	39
Route Setting With 3 Point Motors, 4 Push Buttons and A Super Panel	48
Controlling A Double Slip Using Four Push To Make Switches	62
Controlling Two Separate Solenoid Points Motors Using Two On-Off Toggle Switches	72

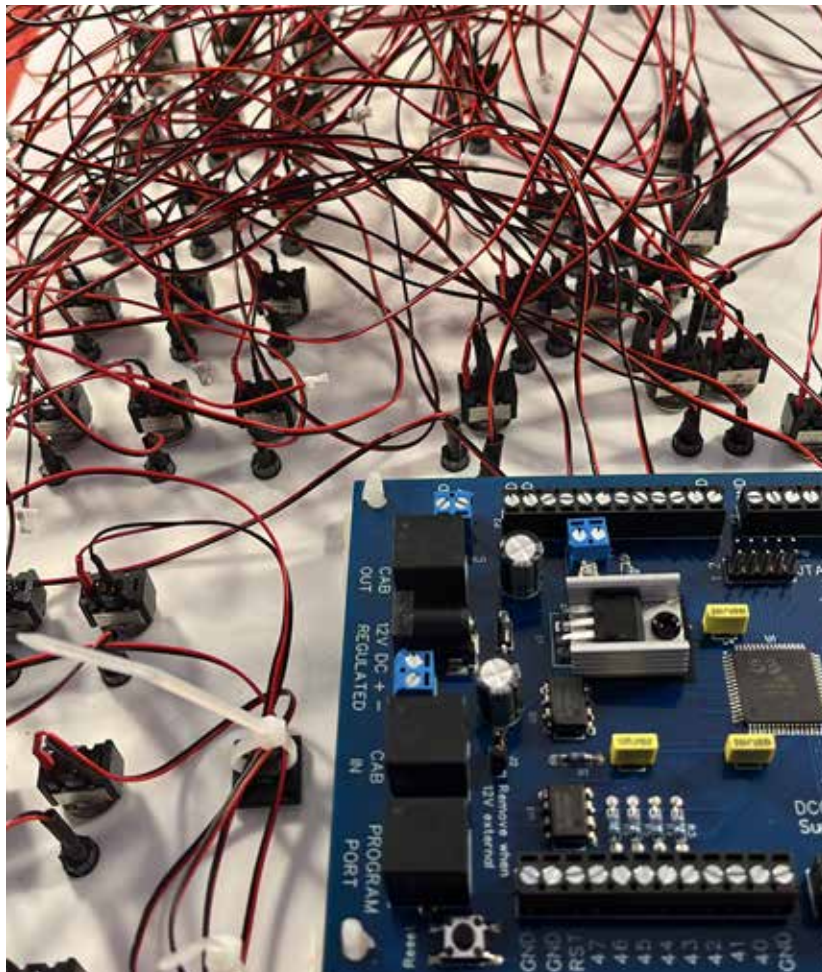

Super Panel is an extremely powerful piece of hardware and we will never be able to document all the possible uses of the product. Over the next 4 manuals we will endeavour to show sample programming for various solutions. With a little bit of thinking they can be used as a starting point for other projects you may think of.

In these guides we will endeavour to show you a step by step guide to some practical uses of the Super Panel.

These will include, in separate volumes:

Point Motor Control

Locomotive Control

Block Control

At the end of each sample we will include a complete parts list of everything we used. Please note, this is by no means the only components you could use, and the benefit of the Super Panel is its ability to interface with various types of switches and components.

Once you have programmed a few different switch types, controlling various point motors you will see the process is straight forward and logical.

It is always advisable to write out before hand, using the sheets at the end of the Super Panel User Guide, each step you are going to program. This way, you shouldn't miss out any crucial steps in your command structure.

In all these guides we will presume the Super Panel is configured correctly for the operation you wish to undertake. For example, the CAB address is correct and the range of inputs is specified. If you are unsure about any of these initial step up commands, please revisit the Super Panel User Guide and re-read the relevant pages.

Some general ideas to think about before moving on...

The inputs on the Super Panel we have picked are just for reference and **DO NOT** mean you **MUST** use these! You can use connect **ANY** input on the Super Panel to control pretty much any DCC accessory.

The same is true of the DCC accessory addresses we have used, these can be anything within the NRMA specified DCC accessory range of 1 to 2044.

We have tried to show samples of what we consider most common uses of the Super Panel. Again we have only just scratched the surface of what it can do, but we hope you will start to understand the programming steps required and the logical process to thinking through for the various steps needed to control various point motors.

Please feel free to email a question and we will get an answer back to you promptly, all we ask is please be patient as it is complicated piece of kit.

As you become familiar with programming and the steps you need, you will realise there are various short-cuts that can be used. In this manual we have purposely shown you the long way round to programme the Super Panel. We think it is important to understand how the information is added before you start cutting corners.

Further manuals, help sheets, data sheets, uses, tips and use will be added to the the Layout Concepts website in due course.

Have fun and let us know how you get on!

Chris



Sample 1

Single Point Control Using One On-Off Toggle Switch

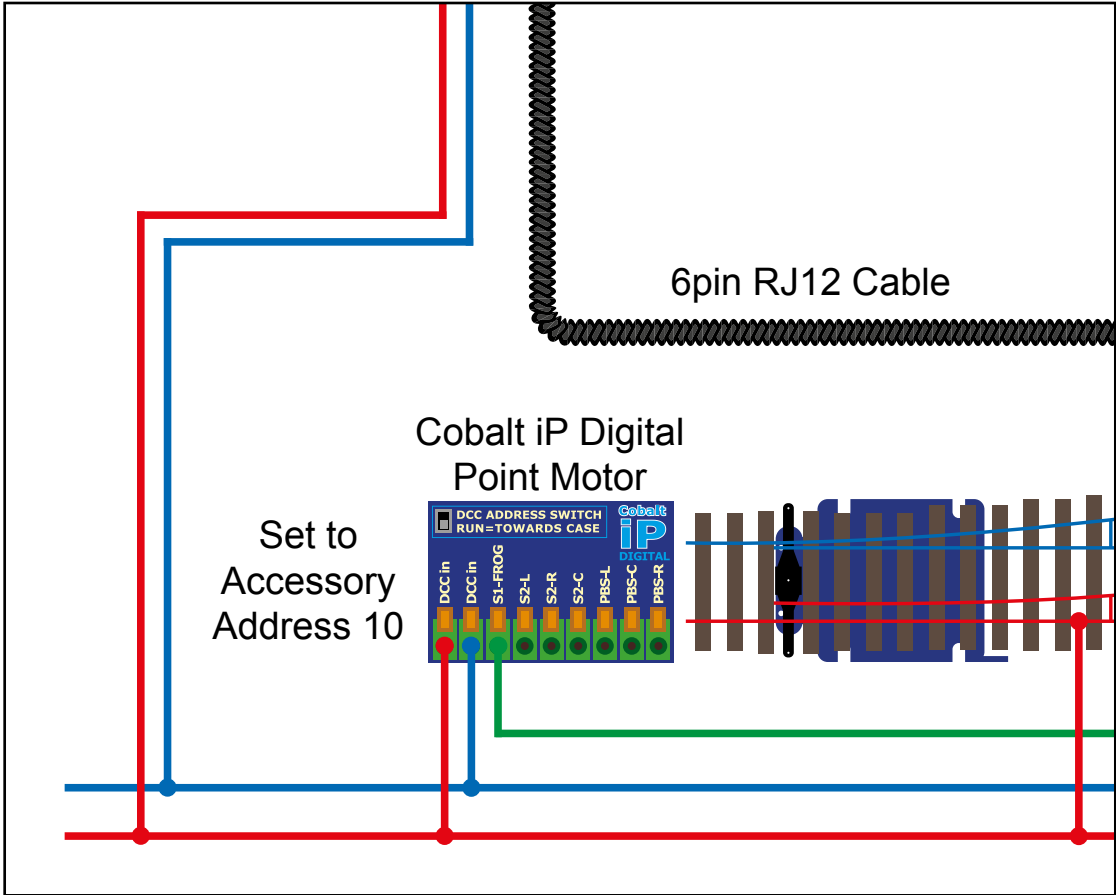

Single Point Control Using One On-Off Toggle Switch

Sample 1

PowerCab Programming Set Up

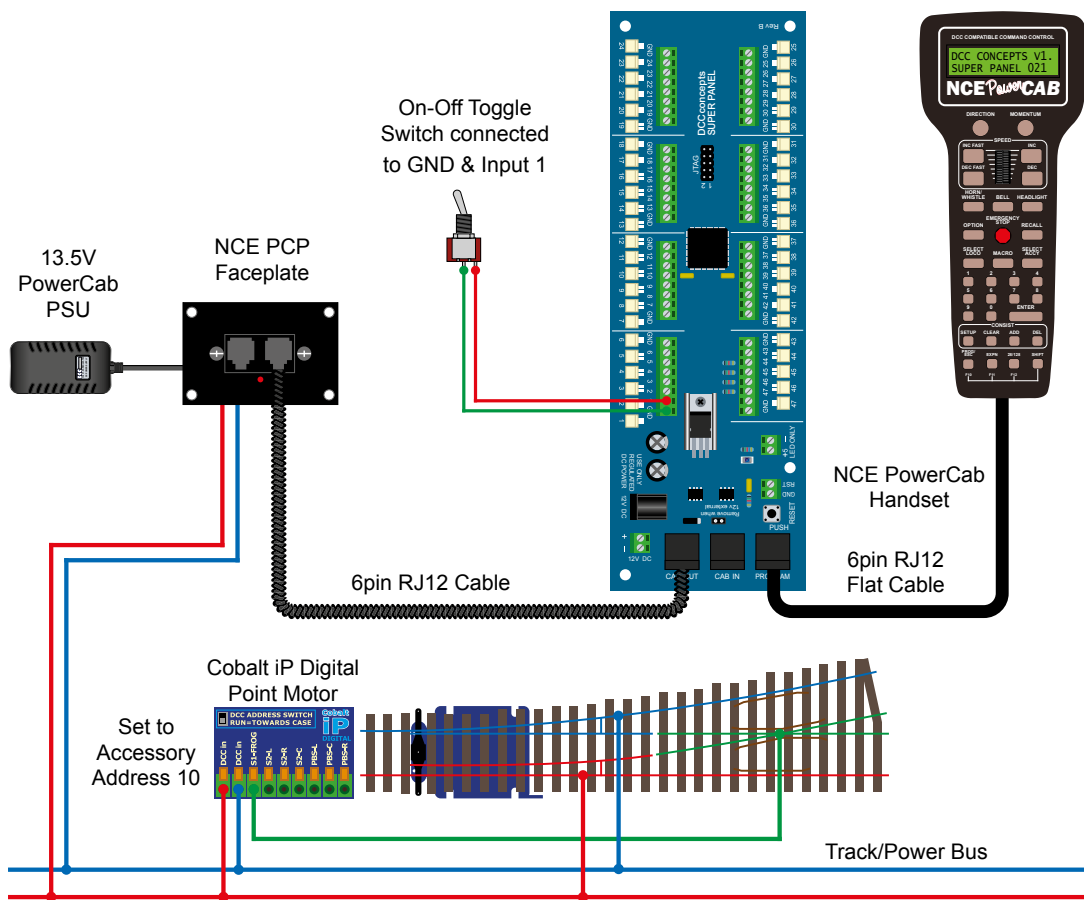

Power Pro Programming Set Up

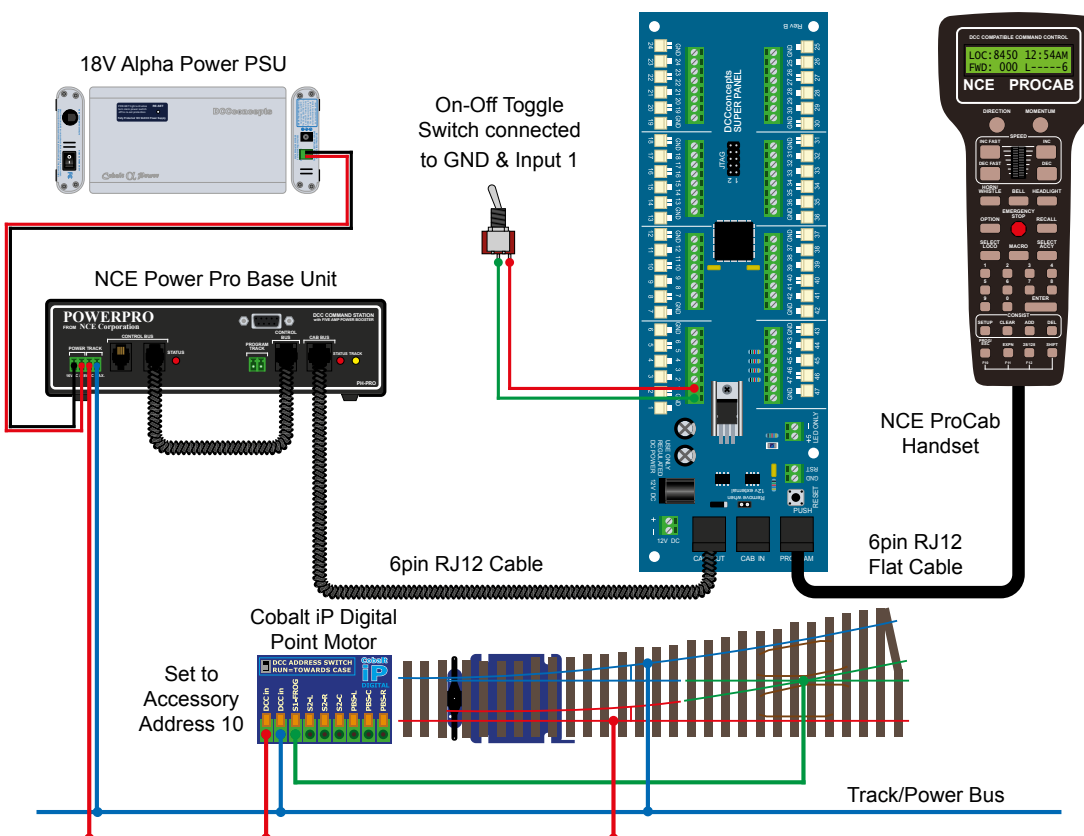

In this first section we will show how to program the Super Panel to control a single digital accessory, in this case a Cobalt iP Digital point motor from an On-Off toggle switch.

The On-Off toggle switch is connected with the centre common to one of the Super Panel ground connections, and the switched connection to Input 1 on the Super Panel.

The Cobalt iP Digital point motor is connected to the normal track/power bus from the NCE system, and has been assigned digital accessory address 10.

One thing to note is that the switched input on the Super Panel could be any of the 47 physical inputs, we are just using Input 1 as a starting point, but the switch could easily be connected to Input 32. The same for the DCC accessory address of the point motor, SuperPanel is happy to control any recognised address or addresses on your DCC system.

Step 1

Connect everything as per the above diagram and the **START SCREEN** will appear, press **ENTER** to move to the **Main Menu**:

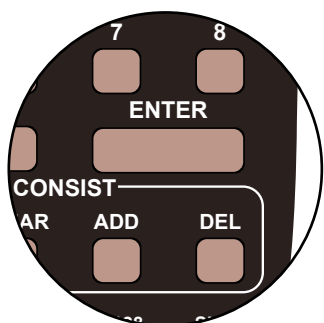

Start Screen

DCC CONCEPTS V1.
SUPER PANEL 025B

Press

ENTER

1=SETUP 2=REVIEW
3=TEST OPERATION

Step 2

Select **1=SETUP** by pressing **1**, and then **1=SET INPUT** by pressing **1**:

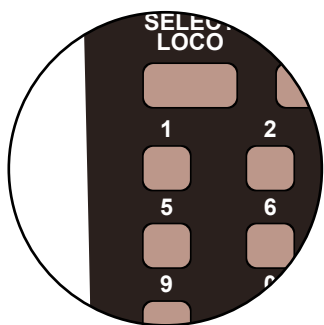

Press

1

THEN

Press

1

1=SETUP INPUT
2=SETUP CONFIG

SETUP INPUT MENU
INPUT:1 LO/HI:L

Step 3

First we set what the switch will do when it is **LOW** or **ON**, so leave the **LO/HI** at **L**. Next select **INPUT:1**, the Super Panel input you have connected the switched terminal from the toggle switch to, by pressing **1** and **ENTER**, and then select **STEP:1** by pressing **ENTER**:

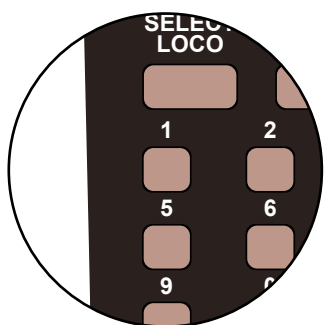

Press

1

THEN

ENTER

THEN

ENTER

INPUT:1 LOW
STEP: 1

INP:1 L STEP:1
1=ACCY 2=MACRO >

Step 4

We have to tell the Super Panel what the device we are controlling from **INPUT 1** is. The point motor is an accessory so press **1**, then confirm the accessory number, **10**, of the motor by pressing **1** then **0** and **ENTER**.

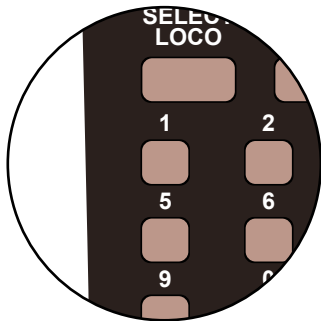

Press
1
Then Press
1
Then Press
0
Then Press
ENTER

```
INP:1  L STEP:1
ACCY NUMBER:10
```

```
INP:1  L STEP:1
NORM/REV : N/1
```

Step 5

We next program the direction of the point motor, either **N/1** - straight or **R/2** - switched. This is done by using the **DIRECTION** key, if needed. We want **N/1**, so leave the settings as show on the screen and then **ENTER** to finish these settings.



Press
DIRECTION
THEN
Press
ENTER

```
INP:1  L STEP:1
NORM/REV : N/1
```

```
INP:1  L STEP:2
1=ACCY 2=MACRO >
```

Step 6

We always finish the command line with an **END** command, then the Super Panel knows it has reached the end of this particular sequence. So press **0** to select **END** and press **ENTER**. Push the **PROG/ESC** key 2 times to return to the **SET INPUT MENU SCREEN**

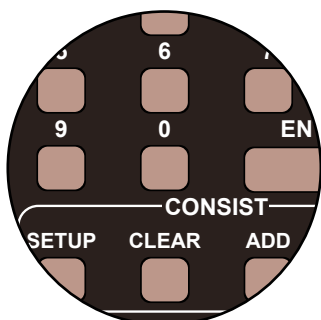

Press
0
THEN
Press
ENTER

```
INP:1  L STEP:2
END: PRESS ENTER
```

```
INP:1  L STEP:3
1=ACCY 2=MACRO >
```

Press **ENTER**. Push the **PROG/ESC** key 2 times to return to the **SET INPUT MENU SCREEN**

Step 7

We now need to program the Super Panel to recognise what happens when the switch is in the **HIGH** or **OFF** position. We are already on **INPUT:1** so to select the high area push the **DIRECTION** key and press **ENTER**. Select **STEP:1** by pressing **ENTER** again.



Press
DIRECTION
Then Press
ENTER
Then Press
ENTER

```
SETUP INPUT MENU  
INPUT:1 LO/HI:L
```

```
SETUP INPUT MENU  
INPUT:1 LO/HI:H
```

```
INPUT:1 HIGH  
STEP: 1
```

Step 8

We want to control the same point motor, which is accessory number 10, so first select the accessory instruction by press **1** and then accessory number 10 should still be shown on the screen, accept this by pressing **ENTER**

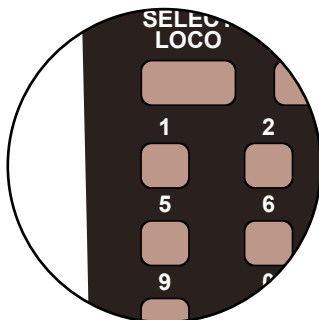

Press
1
THEN
Press
ENTER

```
INP:1 H STEP:1  
1=ACCY 2=MACRO >
```

```
INP:1 H STEP:1  
ACCY NUMBER:10
```

Step 9

We want the point motor to move in the opposite direction this time, **R/2** - switched. This is done by using the **DIRECTION** key and then **ENTER** to finish these settings.



Press
DIRECTION
THEN
Press
ENTER

```
INP:1 H STEP:1  
NORM/REV : N/1
```

```
INP:1 H STEP:1  
NORM/REV : R/2
```

Step 10

As before we always finish the command line with an **END** command, then the Super Panel knows it has reached the end of this particular sequence. So press **0** to select **END** and press **ENTER**.

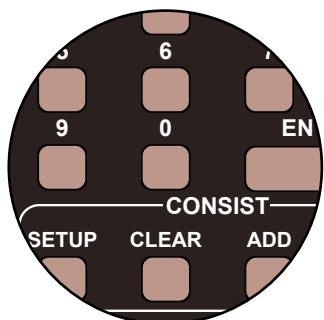

Press
0
THEN
Press
ENTER

INP:1 H STEP:2
END: PRESS ENTER

INP:1 H STEP:3
1=ACCY 2=MACRO >

Push the **PROG/ESC** key 4 times to return to the **SET UP MENU SCREEN**

Before you can run your program from the SuperPanel you need to reconnect the NCE system to the appropriate input on either the Super Panel or your faceplate. If you have two NCE PowerCab or ProCab handsets you can leave one handset connected to the faceplate or CAB BUS and one to the PROGRAM port at all times, saving you from unplugging and plugging constantly.

PowerCab Run Set Up

Power Pro Run Set Up

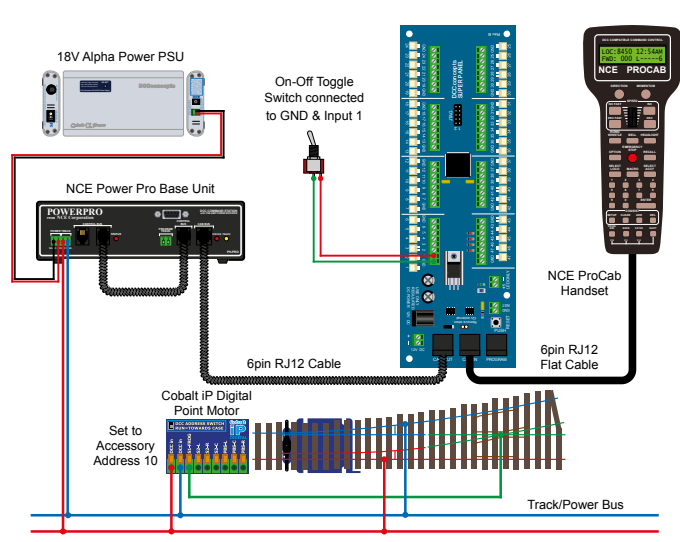
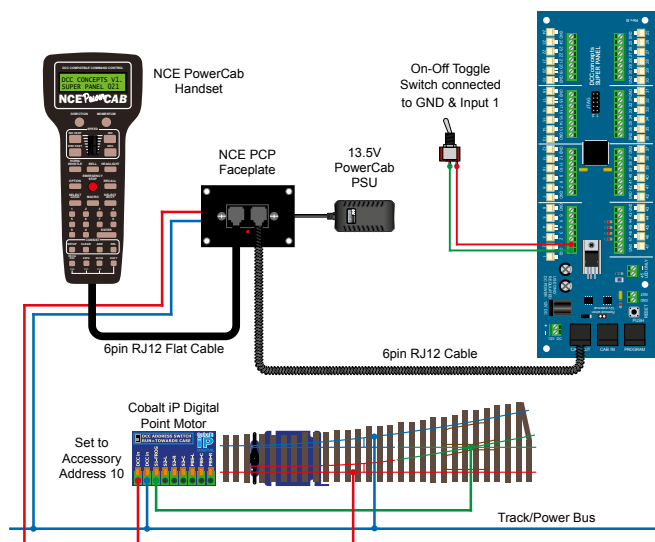

Once you become familiar with programming the Super Panel you may find it easier to write out the commands in tabular form so that you can check your logic. This can then be used to input commands to the Super Panel quickly through the NCE keypad - see below for the keystrokes table for **SAMPLE 1**.

Input No 1			
Select the Input to Input 1		1, ENTER, 1, 1, ENTER	
Step	Keystrokes	LOW Action	HIGH Action
1	1, 10, ENTER, 1, ADD	Accessory 10 Normal	Accessory 10 Reverse
2	0, ADD	End	End

Please note: This command stream use the **ADD** key instead of the **ENTER** key to duplicate the opposite action in the **HIGH** column when entering data in the **LOW** column, or vice versa.

See the bottom of Page 39 - 7.1 ACCY - 1 = Accessory Number in the full Super Panel User Guide for more information on how to achieve this.

Sample 1 - Layout Concepts Parts List

Qty	Part No	Description
1 x	DCC-SPL	Super Panel Control Board
1 x	DCD-ETS	ESP Toggle 6-Pack of On-On Toggle Switches
1 x	DCP-CB1DiP	Cobalt iP Digital Point Motor Single Pack
2 x	DCD-ACL	RJ12 6pin Curly Cord For NCE Powercab and Cobalt Alpha
1 x		Left or right hand point - various makes can be used

Various cable and connectors

Don't forget, you will also need an NCE system, either a PowerCab or PowerPro, to be able to program and run the Super Panel.

You have now setup your first switch to an input to control a digital accessory on your Super Panel! We will now move on to some more complex solutions.

Dual Point Control Using One On-Off Toggle Switch

Sample 2

PowerCab Programming Set Up

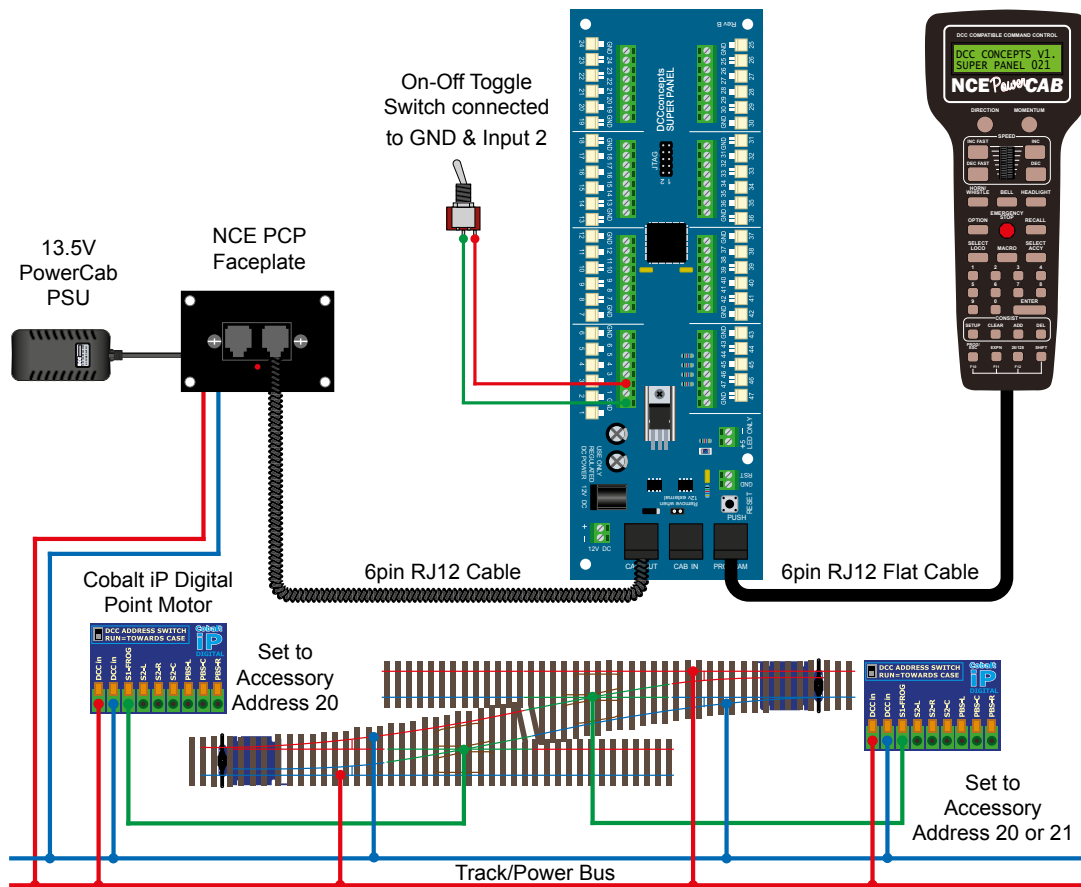

Power Pro Programming Set Up

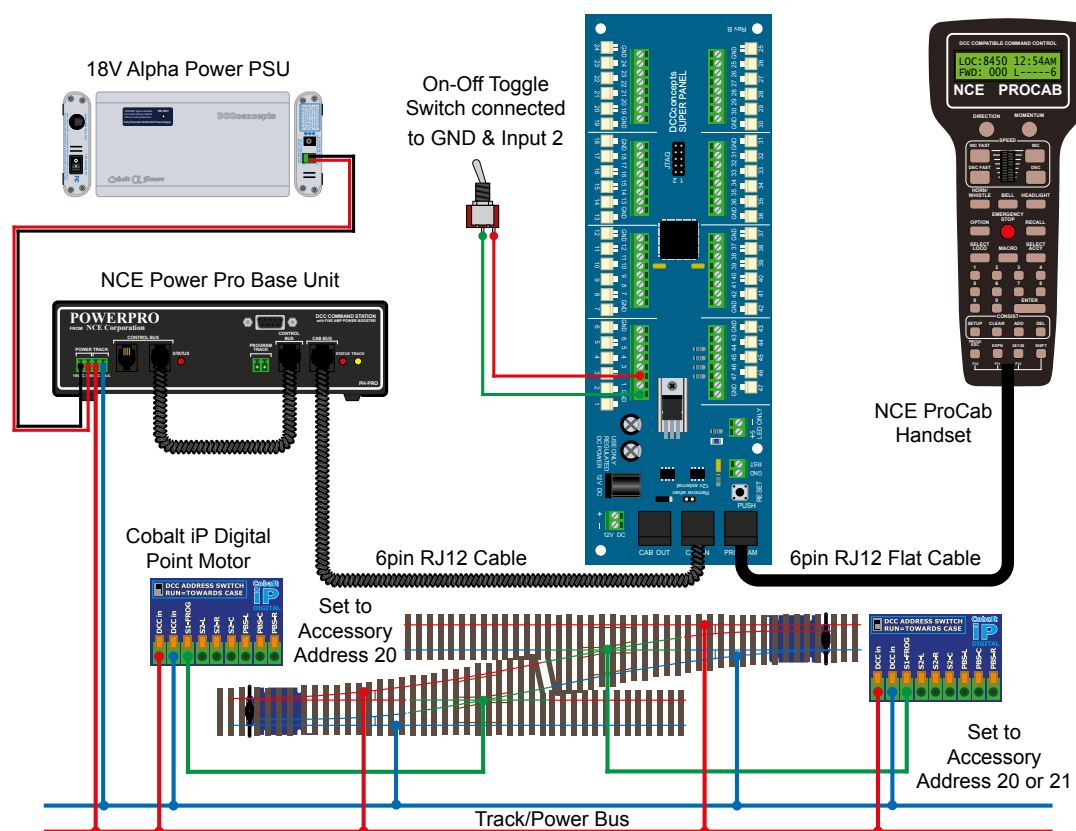

There will be cases where you need one switch to control 2 point motors, both to operate at the same time, i.e. a crossover.

Programming for the Super Panel is exactly the same as in **Sample 1**. The only difference is adding a second point motor, and giving it the same digital accessory address as the first.

The motors will need to work in opposite directions. This can be achieved by locating the motors in physically the opposite direction or, if available a reversing command on the actual point motor i.e. the 197 command on the Cobalt iP Digital point motor.

You could also get the Super Panel to send out a second command, **STEP 2** from **INPUT 1** after the first command to change the second point. Make sure you give this second point motor a different Accessory Address, say 21, so it doesn't respond to **STEP 1** of the command structure.

STEP 2 on **INPUT 2** will send out the same commands as **STEP 1** but the direction of movement of the second point motor, Accessory Address 21, will be the opposite from **STEP 1**.

Have a go and see how you get on!

Before you can run your program from the SuperPanel you need to reconnect the NCE system to the appropriate input on either the Super Panel or your faceplate. If you have two NCE PowerCab or ProCab handsets you can leave one handset connected to the faceplate or CAB BUS and one to the PROGRAM port at all times, saving you from unplugging an plugging constantly.

PowerCab Run Set Up

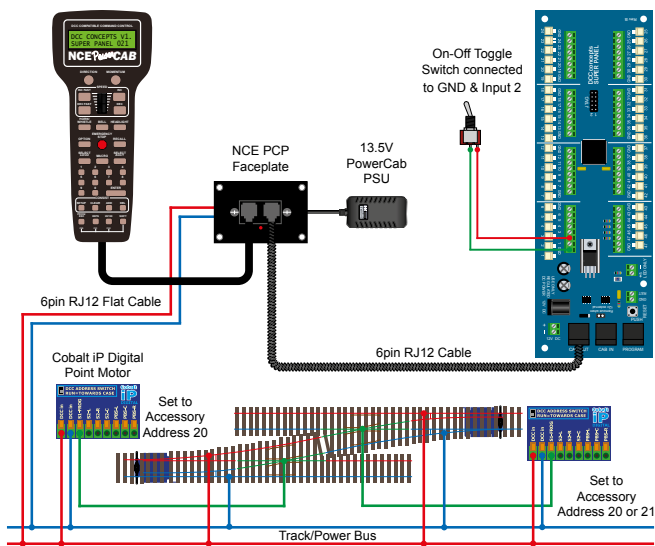

Power Pro Run Set Up

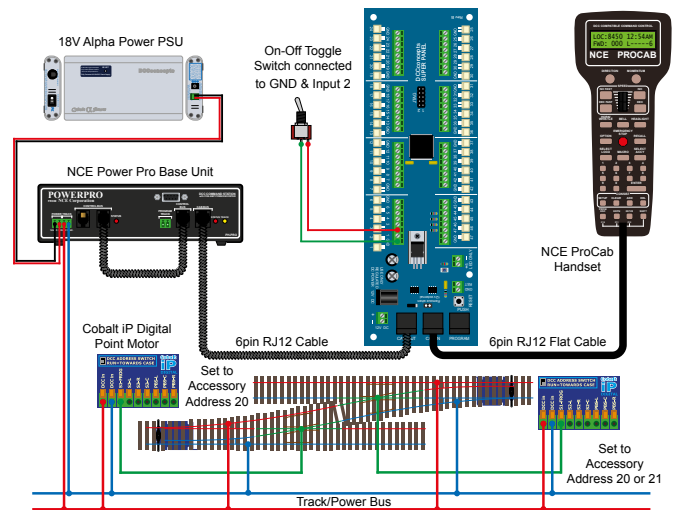

Once you become familiar with programming the Super Panel you may find it easier to write out the commands in tabular form so that you can check your logic. This can then be used to input commands to the Super Panel quickly through the NCE keypad - see the next page for the keystrokes table for **SAMPLE 2**.

Input No 2			
Select the Input to Input 2		1, 1, 2, ENTER, 1, ENTER	
Step	Keystrokes	LOW Action	HIGH Action
1	1, 20, ENTER, 1, ADD	Accessory 20 Normal	Accessory 20 Reverse
2	1, 21, ENTER, 1, ADD	Accessory 21 Normal	Accessory 21 Reverse
3	0, ADD	End	End

Please note: This command stream use the **ADD** key instead of the **ENTER** key to duplicate the opposite action in the **HIGH** column when entering data in the **LOW** column, or vice versa.

See the bottom of Page 39 - 7.1 ACCY - 1 = Accessory Number in the full Super Panel User Guide for more information on how to achieve this.

Sample 2 - Layout Concepts Parts List

Qty	Part No	Description
1 x	DCC-SPL	Super Panel Control Board
1 x	DCD-ETS	ESP Toggle 6-Pack of On-On Toggle Switches
2 x	DCP-CB1DiP	Cobalt iP Digital Point Motor Single Pack
2 x	DCD-ACL	RJ12 6pin Curly Cord For NCE Powercab and Cobalt Alpha
2 x	Left or right hand points - various makes can be used	

Various cable and connectors

Don't forget, you will also need an NCE system, either a PowerCab or PowerPro, to be able to program and run the Super Panel.

You have now configured your Super Panel to control 2 separate point motors from one On-Off toggle switches.

Controlling Two Separate Points Using Two On-Off Toggle Switches

Sample 3

PowerCab Programming Set Up

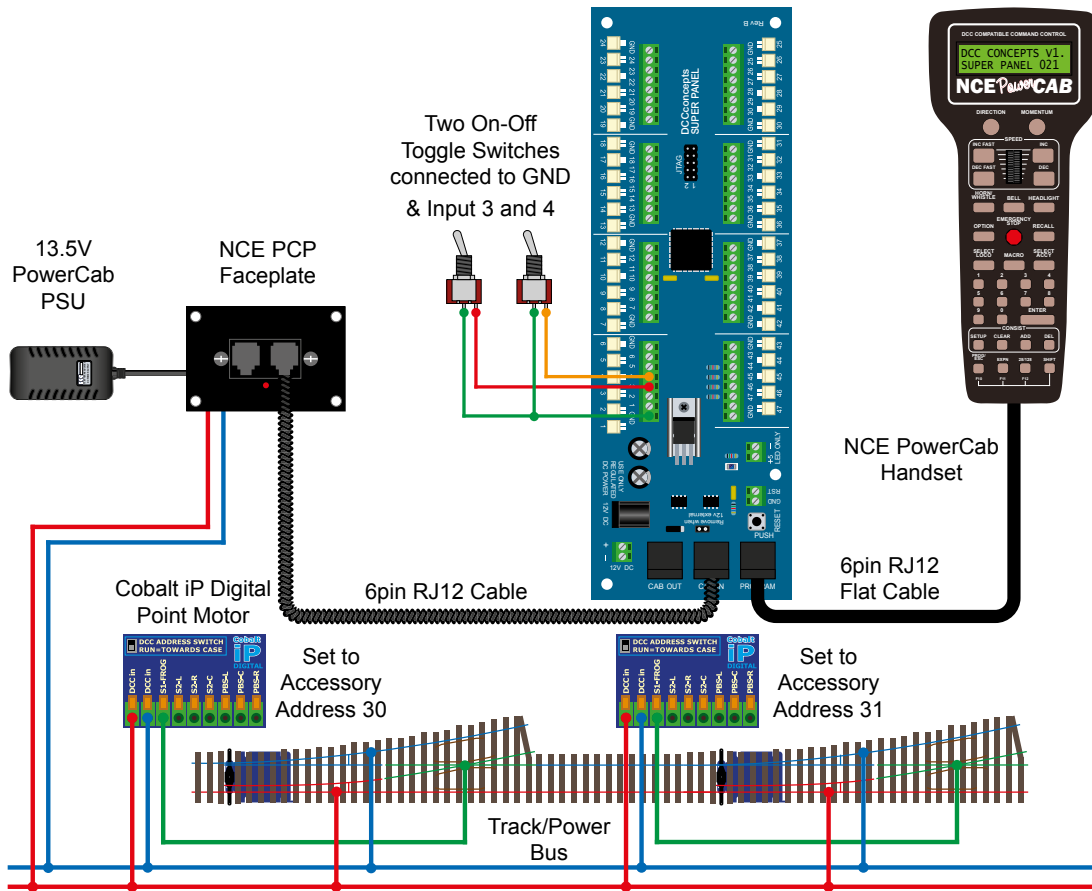

Power Pro Programming Set Up

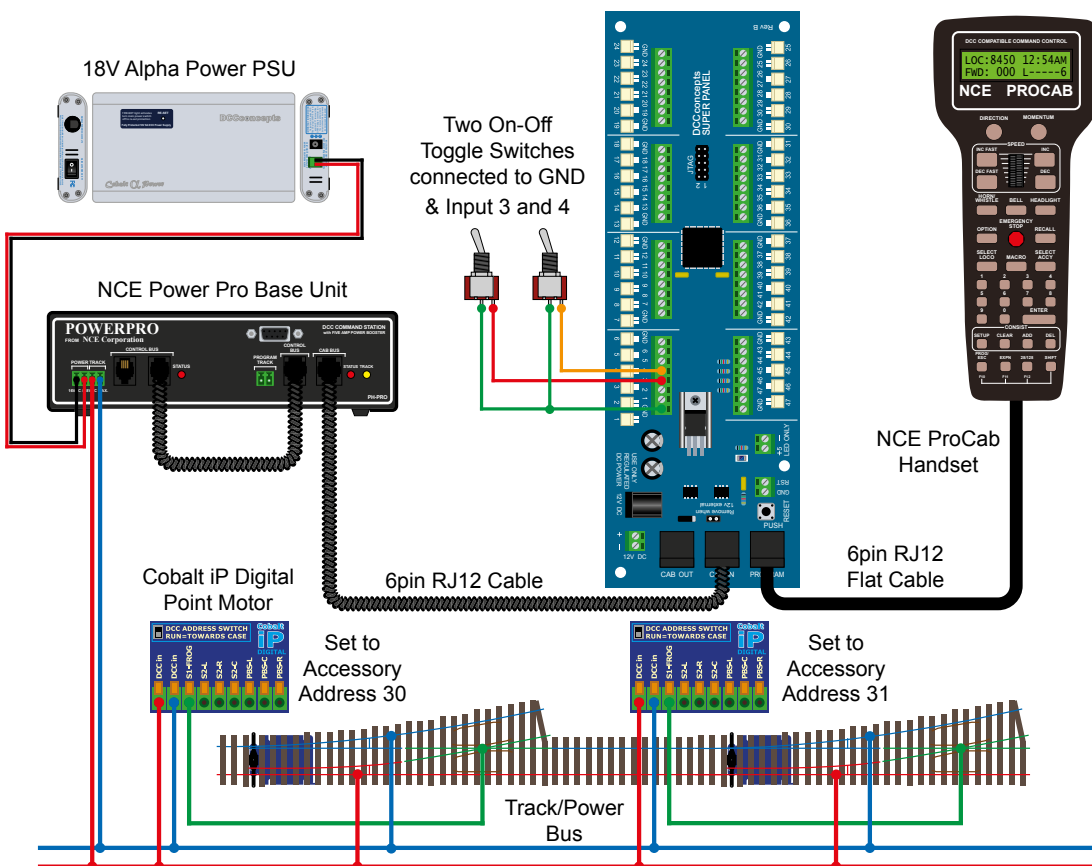

This sample shows how to program two On-Off switches to control two separate point motors.

The first On-Off toggle switch is connected with the centre common to one of the Super-Panel ground connections, and the switched connection to Input 3 on the Super Panel.

The Cobalt iP Digital point motor is connected to the normal track/power bus from the Power Pro base unit, and has been assigned digital accessory address 20.

The second On-Off toggle switch is connected with the centre common to one of the Super-Panel ground connections, and the switched connection to Input 4 on the Super Panel.

The Cobalt iP Digital point motor is connected to the normal track/power bus from the Power Pro base unit, and has been assigned digital accessory address 21.

Step 1

To set up Switch 1 on Input 3 follow **STEPS 1 to 8** from **SAMPLE 1** to configure the first switch with the first point motor on digital address 30.

We now need to set up the second switch on the Super-Panel, which is connected to Input 4 and controlling the point motor set to digital address 31.

Step 2

Select **1=SETUP** by pressing **1**, and then **1=SET INPUT** by pressing **1**, press the **DIRECTION** key to select **LO/HI:L** if needed and then press **ENTER**:

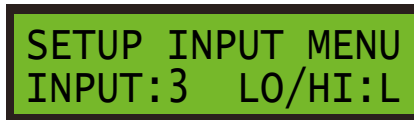
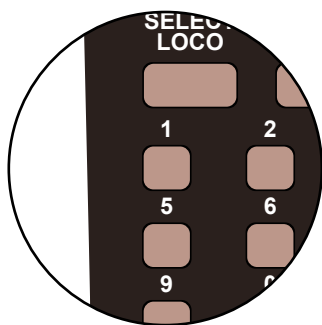

Step 3

We need to set the command for the connection on Super-Panel **INPUT 4**, so press **4** and for the **LOW/HIGH** option leave it set to **LOW**, hence **LO/HI:L** and press **ENTER**:

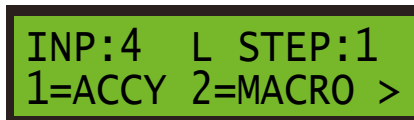
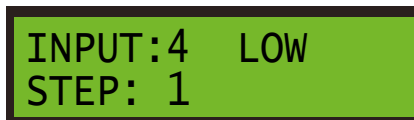
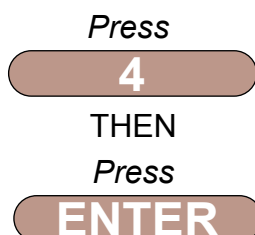
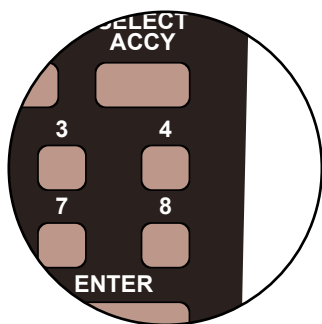

Step 4

We have to tell the Super Panel what the device we are controlling from **INPUT 4** is. The point motor is an accessory so press **1**, then confirm the accessory number, **31**, of the motor by pressing **3** then **1** and, press **ENTER**:

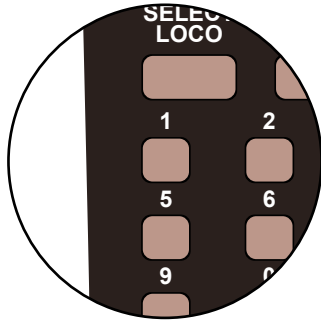

Press
1
Then Press
3
Then Press
1
Then Press
ENTER

```
INP:4  L STEP:1  
ACCY NUMBER:31
```

```
INP:4  L STEP:1  
NORM/REV : N/1
```

Step 5

We always finish the command line with an **END** command, then the Super Panel knows it has reached the end of this particular sequence. So press **0** to select **END** and press **ENTER**. Push the **PROG/ESC** key 2 times to return to the **SET INPUT MENU SCREEN**

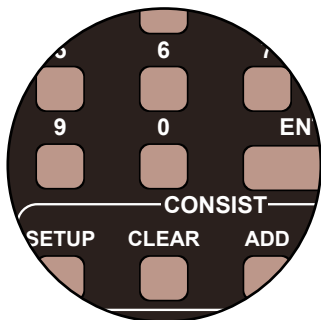

Press
0
THEN
Press
ENTER

```
INP:4  L STEP:2  
END: PRESS ENTER
```

```
INP:4  L STEP:3  
1=ACCY 2=MACRO >
```

Step 6

Push the **PROG/ESC** key 2 times to return to the **SET UP INPUT MENU SCREEN**. We next program the direction of the point motor, we want **N/1**, so press the **DIRECTION** key to select **N/1** if needed: and then **ENTER** to finish these settings.



Press
DIRECTION
THEN
Press
ENTER

```
SETUP INPUT MENU  
INPUT:4  LO/HI:L
```

```
SETUP INPUT MENU  
INPUT:4  LO/HI:H
```

Step 7

We need to tell the Super-Panel what to do when the **ON-OFF** toggle switched is switched **OFF**, so from the **SETUP INPUT MENU SCREEN**, push the **DIRECTION** key to change Input 1 to look at the **HIGH/OFF** command, and press **ENTER**. Select **STEP 1** and press **ENTER**.



Press
DIRECTION
THEN
Press
ENTER

```
SETUP INPUT MENU  
INPUT:4 LO/HI:H
```

```
INPUT:4 HIGH  
STEP: 1
```

Step 8

As before we are controlling accessory number **31** from **INPUT 4**, so select accessory by pressing **1** and enter accessory number **31** by pressing **3** then **1**, and then press **ENTER**

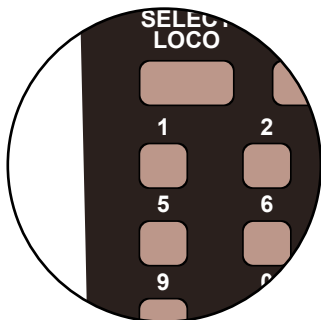

Press
1
Then Press
3
Then Press
1
Then Press
ENTER

```
INP:4 H STEP:1  
1=ACCY 2=MACRO >
```

```
INP:4 H STEP:1  
ACCY NUMBER:31
```

```
INP:4 H STEP:1  
NORM/REV : N/1
```

Step 9

This time we want the motor to move the opposite direction than before, so we want **REVERSED/2**. Press the **DIRECTION** key to select **R/2** and then **ENTER** to finish these settings.



Press
DIRECTION
THEN
Press
ENTER

```
INP:4 H STEP:1  
NORM/REV : R/2
```

```
INP:2 H STEP:2  
1=ACCY 2=MACRO >
```

Step 10

As before we always finish the command line with an **END** command, then the Super Panel knows it has reached the end of this particular sequence. So press **0** to select **END** and press **ENTER**.

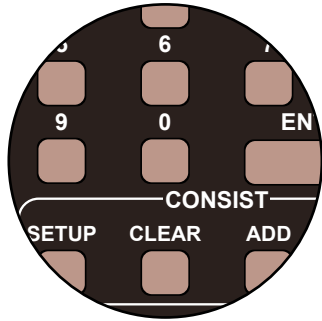

Press
0
THEN
Press
ENTER

INP:4 H STEP:2
END: PRESS ENTER

INP:4 H STEP:3
1=ACCY 2=MACRO >

Push the **PROG/ESC** key 4 times to return to the **SET UP MENU SCREEN**

Before you can run your program from the SuperPanel you need to reconnect the NCE system to the appropriate input on either the Super Panel or your faceplate. If you have two NCE PowerCab or ProCab handsets you can leave one handset connected to the faceplate or CAB BUS and one to the PROGRAM port at all times, saving you from unplugging an plugging constantly.

PowerCab Run Set Up

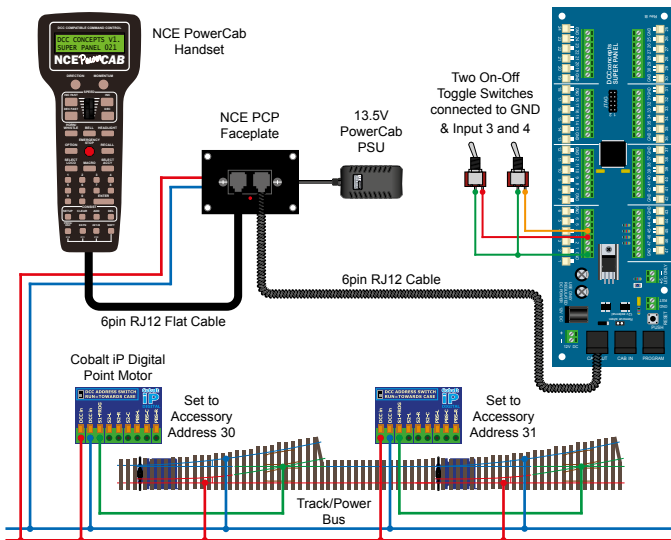

Power Pro Run Set Up

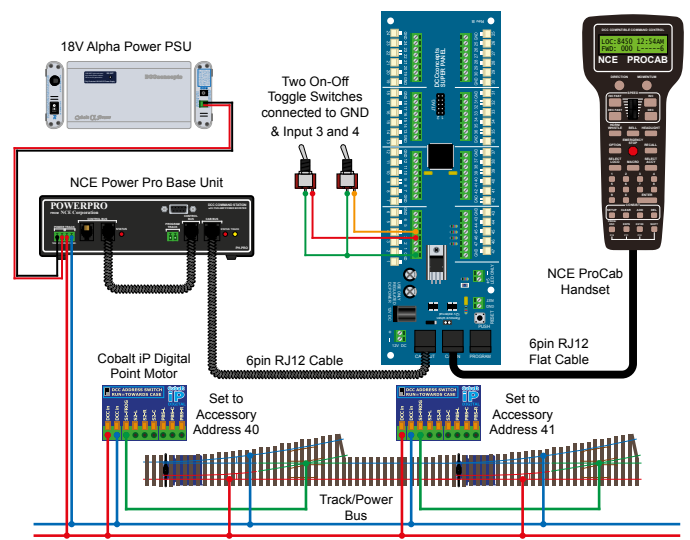

Once you become familiar with programming the Super Panel you may find it easier to write out the commands in tabular form so that you can check your logic. This can then be used to input commands to the Super Panel quickly through the NCE keypad - see the next page for the keystrokes tables for **SAMPLE 3**.

Keystroke table for Input 3:

Input No 3			
Select the Input to Input 3		1, 1, 3, ENTER, 1, ENTER	
Step	Keystrokes	LOW Action	HIGH Action
1	1, 30, ENTER, 1, ADD	Accessory 30 Normal	Accessory 30 Reverse
2	0, ADD	End	End

Keystroke table for Input 4:

Input No 4			
Select the Input to Input 4		1, 1, 4, ENTER, 1, ENTER	
Step	Keystrokes	LOW Action	HIGH Action
1	1, 31, ENTER, 1, ADD	Accessory 31 Normal	Accessory 31 Reverse
2	0, ADD	End	End

Please note: These command streams use the **ADD** key instead of the **ENTER** key to duplicate the opposite action in the **HIGH** column when entering data in the **LOW** column, or vice versa.

See the bottom of Page 39 - 7.1 ACCY - 1 = Accessory Number in the full Super Panel User Guide for more information on how to achieve this.

Sample 3 - Layout Concepts Parts List

Qty	Part No	Description
1 x	DCC-SPL	Super Panel Control Board
1 x	DCD-ETS	ESP Toggle 6-Pack of On-On Toggle Switches
2 x	DCP-CB1DiP	Cobalt iP Digital Point Motor Single Pack
2 x	DCD-ACL	RJ12 6pin Curly Cord For NCE Powercab and Cobalt Alpha
2 x		Left or Right hand points - various makes can be used

Various cable and connectors

Don't forget, you will also need an NCE system, either a PowerCab or PowerPro, to be able to program and run the Super Panel.

You have now configured your Super Panel to control 2 separate point motors from two separate On-Off toggle switches.

To add further switches and point motors you just repeat this process, making sure you select the correct input to the Super Panel and the correct digital address for the accessory.

Sample 4

Controlling A 3-Way Point Using Three Push To Make Switches

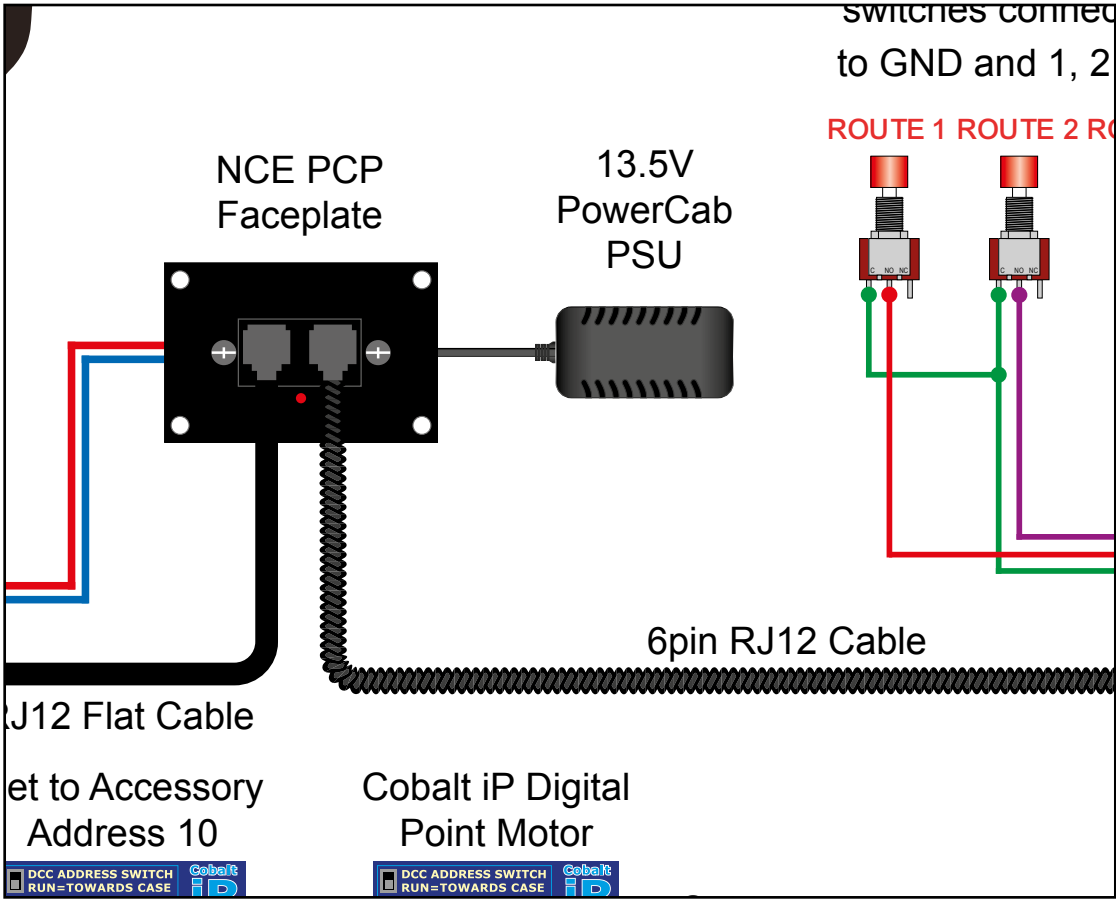

Controlling A 3-Way Point Using Three Push To Make Switches

Sample 4

PowerCab Programming Set Up

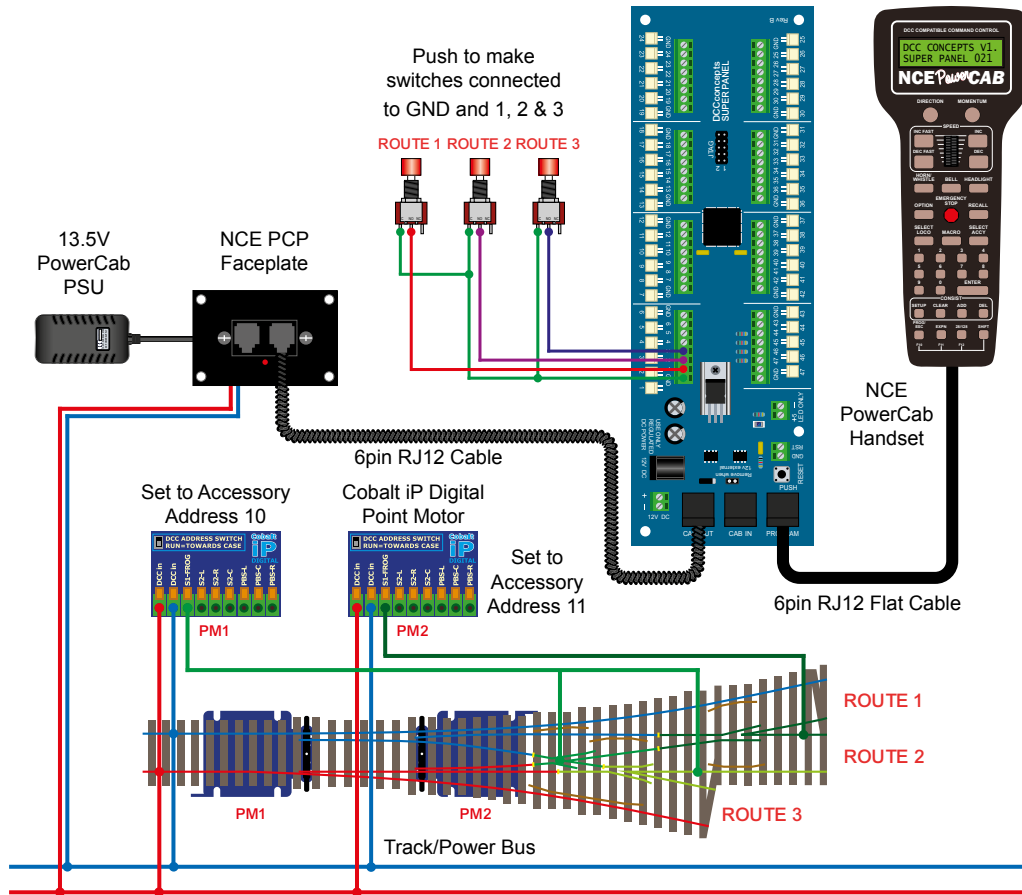

Power Pro Programming Set Up

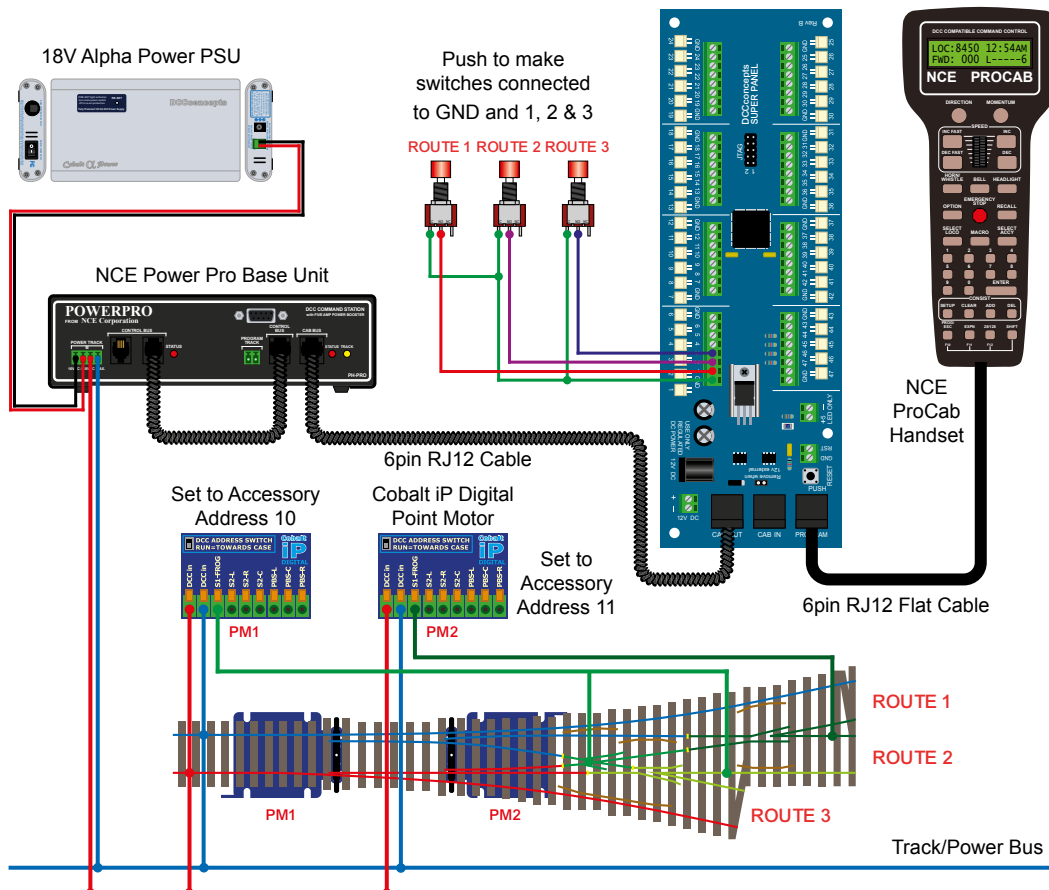

In this sample we will control a 3-way point with separate push to make switches. The separate routes will be each controlled from a single push to make switch on each route.

To select **Route 1**, we need to set Point 1, **PM1** to **NORMAL** and Point 1, **PM2** to **NORMAL**.
 To select **Route 2**, we need to set Point 1, **PM1** to **NORMAL** and Point 2, **PM2** to **REVERSED**.
 To select **Route 3**, we need to set Point 1, **PM1** to **REVERSED** and Point 2, **PM2** to **REVERSED**.

Step 1

First we need to set Route 1 - so setting **Point 1, PM1** first, we connect everything as per the diagram and the **START SCREEN** will appear, press **ENTER** to move to the **Main Menu**:

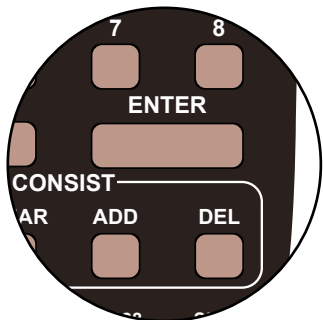

Start Screen

DCC CONCEPTS V1.
SUPER PANEL 025B

Press

ENTER

1=SETUP 2=REVIEW
3=TEST OPERATION

Step 2

Select **1=SETUP** by pressing **1**, and then **1=SET INPUT** by pressing **1**:

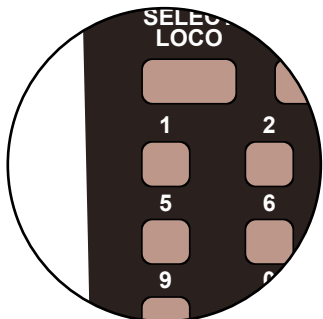

Press

1

THEN

Press

1

1=SETUP INPUT
2=SETUP CONFIG

SETUP INPUT MENU
INPUT:1 LO/HI:L

Step 3

Set **INPUT:1** push to make switch to **LOW**, by pressing **DIRECTION** and **ENTER**, and then select **STEP:1** by pressing **ENTER**:

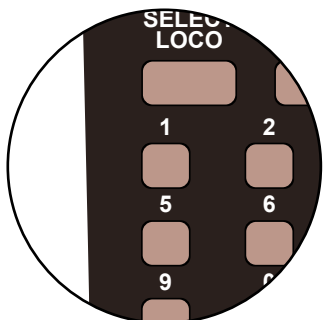

Press

1

THEN

ENTER

Press

ENTER

INPUT:1 LOW
STEP: 1

INP:1 L STEP:1
1=ACCY 2=MACRO >

Step 4

The point motor is an accessory so press **1**, then confirm the accessory number, **10**, of the motor by pressing **1** then **0** and **ENTER**.

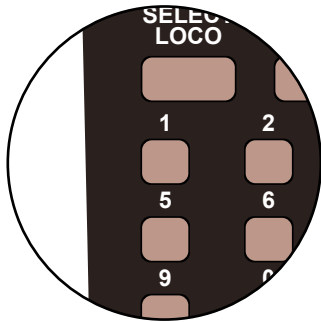

Press

1

Then Press

1

Then Press

0

Then Press

ENTER

```
INP:1  L STEP:1
ACCY NUMBER:10
```

```
INP:1  L STEP:1
NORM/REV : N/1
```

Step 5

We want the motor to move to the **NORMAL** or **N/1** position, so leave the settings as show on the screen and **ENTER** to save these settings. If needed, you can change from **N/1** to **R/2**, and vice-versa, by pushing the **DIRECTION** key. You are now ready to set **Point 2, PM2** on **INPUT 1**.



Press

DIRECTION

THEN

Press

ENTER

```
INP:1  L STEP:1
NORM/REV : N/1
```

```
INP:1  L STEP:2
1=ACCY 2=MACRO >
```

Step 6

Now we need to set **Point 2, PM2** to work with **Route 1**. This is still **INPUT 1**, on the Super-Panel, and **STEP:2** is showing in the top right of the screen. The point motor, **PM2** is an accessory so press **1**, then confirm the accessory number, **11**, of the motor by pressing **1** then **1** and **ENTER**.

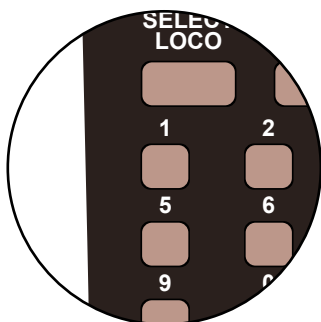

Press

1

Then Press

1

Then Press

1

Then Press

ENTER

```
INP:1  L STEP:2
ACCY NUMBER:11
```

```
INP:1  L STEP:2
NORM/REV : N/1
```

Step 7

We next program the direction of the point motor, we want **N/1**, so press the **DIRECTION** key, if needed, to select **N/1**, and then **ENTER** to finish these settings.

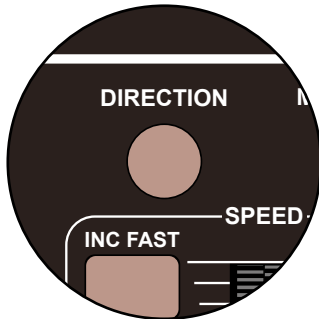

Press
DIRECTION
THEN
Press
ENTER

```
INP:1 L STEP:2  
NORM/REV : N/1
```

```
INP:1 L STEP:3  
1=ACCY 2=MACRO >
```

Step 8

We always finish the command line with an **END** command, then the Super Panel knows it has reached the end of this particular sequence. So press **0** to select **END** and press **ENTER**.

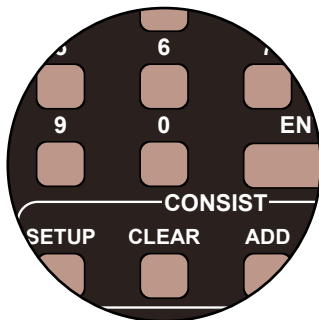

Press
0
THEN
Press
ENTER

```
INP:1 H STEP:3  
END: PRESS ENTER
```

```
INP:1 H STEP:4  
1=ACCY 2=MACRO >
```

Step 9

That is **INPUT 1** set, so move on to **INPUT 2**. Push the **PROG/ESC** key twice to return to the **SETUP INPUT MENU SCREEN**. Select **INPUT 2** by pushing **2** and pressing **ENTER**

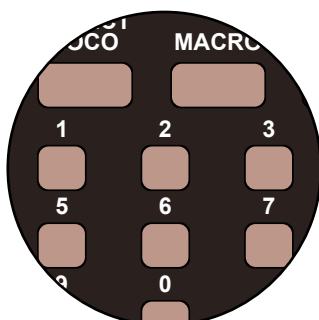

Press
2
THEN
Press
ENTER

```
SETUP INPUT MENU  
INPUT:2 LO/HI:L
```

```
INPUT:2 LOW  
STEP: 1
```

Step 10

Set **INPUT:2** push to make switch to **LOW** by pressing **DIRECTION**, if needed, and then select **STEP:1** by pressing **1** and then **ENTER**, then press **1** for an accessory.

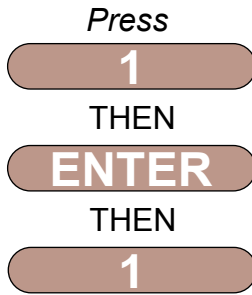
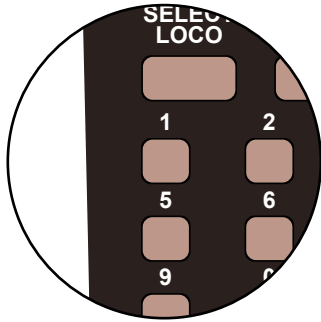

```
INP:2  L STEP:1
1=ACCY 2=MACRO >
```

```
INP:2  L STEP:1
ACCY NUMBER:10
```

Step 11

Select accessory number **10** by pressing **1** then **0** and press **ENTER**:

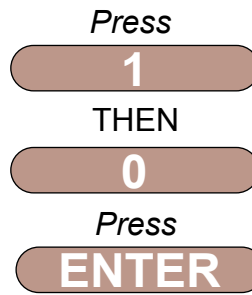
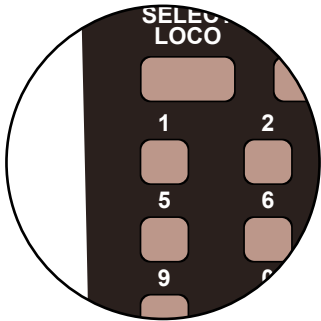

```
INP:2  L STEP:1
ACCY NUMBER:10
```

```
INP:2  L STEP:1
NORM/REV : N/1
```

Step 12

Confirm the **NORMAL** or **N/1** direction of the motor by pressing **ENTER**. Now we program **STEP 2** to control **Point 2, PM2**, by pushing **1** to select an accessory.

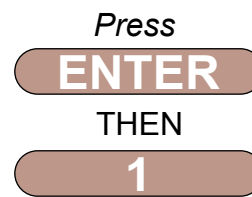
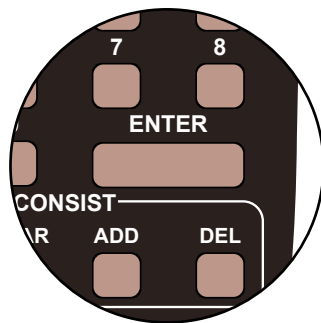

```
INP:2  L STEP:2
1=ACCY 2=MACRO >
```

```
INP:2  L STEP:2
ACCY NUMBER:10
```

Step 13

Select accessory number **11** by pressing **1** and then **1** and then **ENTER**.

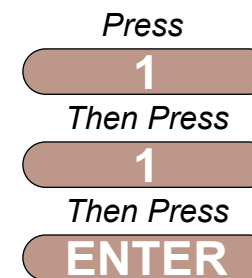
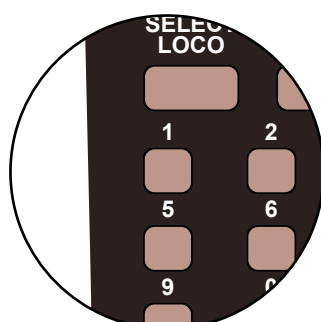

```
INP:2  L STEP:2
ACCY NUMBER:11
```

```
INP:2  L STEP:2
NORM/REV : N/1
```

Step 14

We need the motor to move in the opposite direction, so push the **DIRECTION** key to select **REVERSE** or **R/2** and confirm by pushing **ENTER**.



Press
DIRECTION
Then Press
ENTER

```
INP:2  L STEP:2
NORM/REV : R/2
```

```
INP:2  L STEP:3
1=ACCY 2=MACRO
```

Step 15

We always finish the command line with an **END** command, then the Super Panel knows it has reached the end of this particular sequence. So press **0** to select **END** and press **ENTER**.

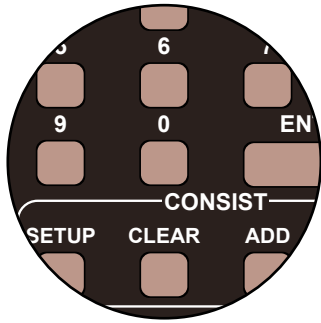

Press
0
THEN
Press
ENTER

```
INP:2  L STEP:3
END: PRESS ENTER
```

```
INP:2  L STEP:4
1=ACCY 2=MACRO >
```

Step 16

That is **INPUT 2** set, so move on to **INPUT 3**. Push the **PROG/ESC** key twice to return to the **SET UP INPUT MENU SCREEN**. Select **INPUT 3** by pushing **3** and pressing **ENTER**

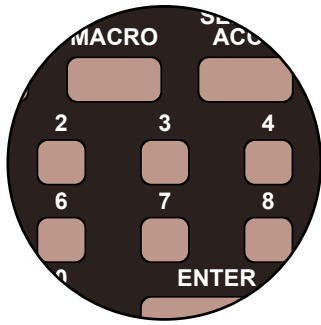

Press
3
THEN
Press
ENTER

```
SETUP INPUT MENU
INPUT:3  LO/HI:L
```

```
INPUT:3  LOW
STEP: 1
```

Step 17

Set **INPUT:3** push to make switch to **LOW** by pressing **DIRECTION**, if needed, and then select **STEP:1** by pressing **ENTER**, then press **1** for an accessory.

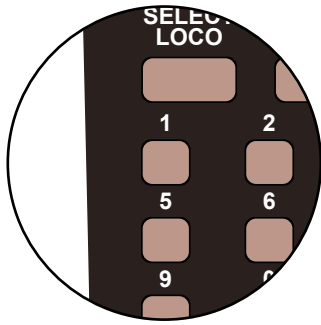

Press
1
THEN
ENTER
THEN
1

```
INP:3  L STEP:1
1=ACCY 2=MACRO >
```

```
INP:3  L STEP:1
ACCY NUMBER:11
```

Step 18

Select accessory number **10** by pressing **1** then **0** and press **ENTER**:

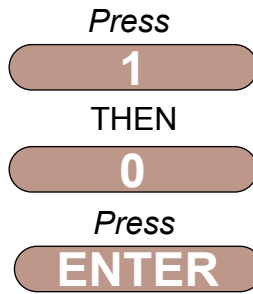
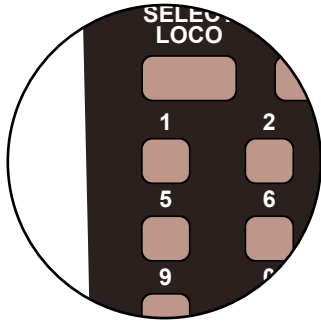

```
INP:3  L STEP:1
ACCY NUMBER:10
```

```
INP:3  L STEP:1
NORM/REV : R/2
```

Step 19

Leave the direction at **REVERSED** or **R/2** of the motor by pressing **ENTER**. Now we program **STEP 2** to control **Point 2, PM2**, by pushing **1** to select an accessory.

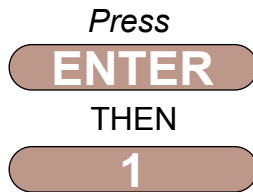
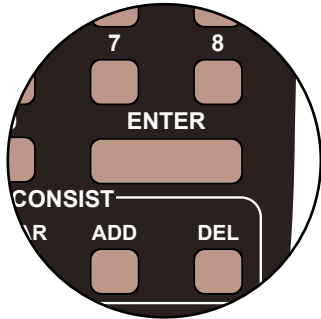

```
INP:3  L STEP:2
1=ACCY 2=MACRO >
```

```
INP:3  L STEP:2
ACCY NUMBER:10
```

Step 20

Select accessory number **11** by pressing **1** and then **1** and then **ENTER**.

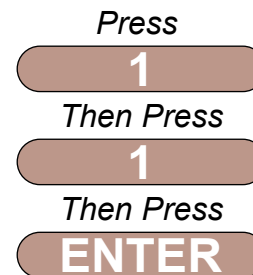
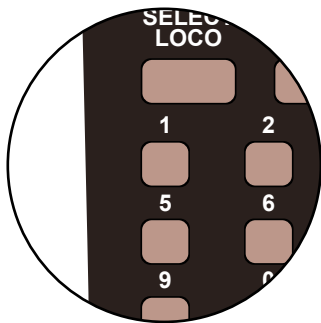

```
INP:3  L STEP:1
ACCY NUMBER:11
```

```
INP:2  L STEP:2
NORM/REV : N/1
```

Step 21

Set the motor to **REVERSE** or **R/2**, so push the **DIRECTION** key to select **REVERSE** or **R/2**, if necessary and confirm by pushing **ENTER**.



```
INP:2  L STEP:2
NORM/REV : R/2
```

```
INP:3  L STEP:3
1=ACCY 2=MACRO >
```

Step 22

We always finish the command line with an **END** command, then the Super Panel knows it has reached the end of this particular sequence. So press **0** to select **END** and press **ENTER**.

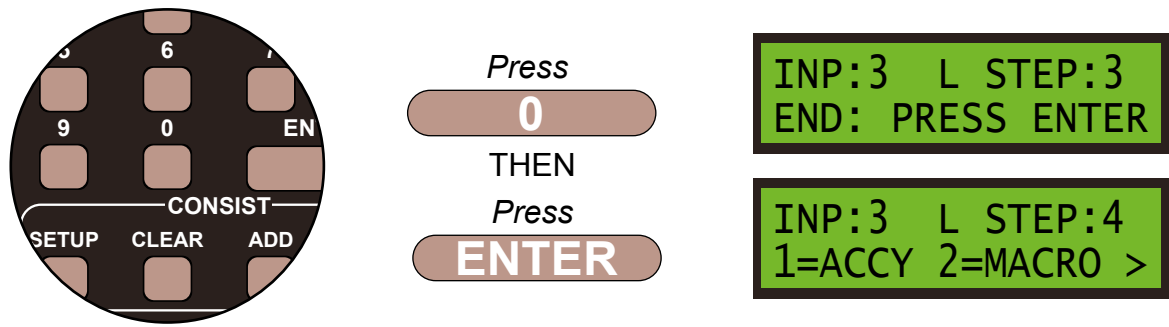

Push the **PROG/ESC** key 4 times to return to the **SET UP MENU SCREEN**.

Before you can run your program from the SuperPanel you need to reconnect the NCE system to the appropriate input on either the Super Panel or your faceplate. If you have two NCE PowerCab or ProCab handsets you can leave one handset connected to the faceplate or CAB BUS and one to the PROGRAM port at all times, saving you from unplugging and plugging constantly.

PowerCab Run Set Up

Power Pro Run Set Up

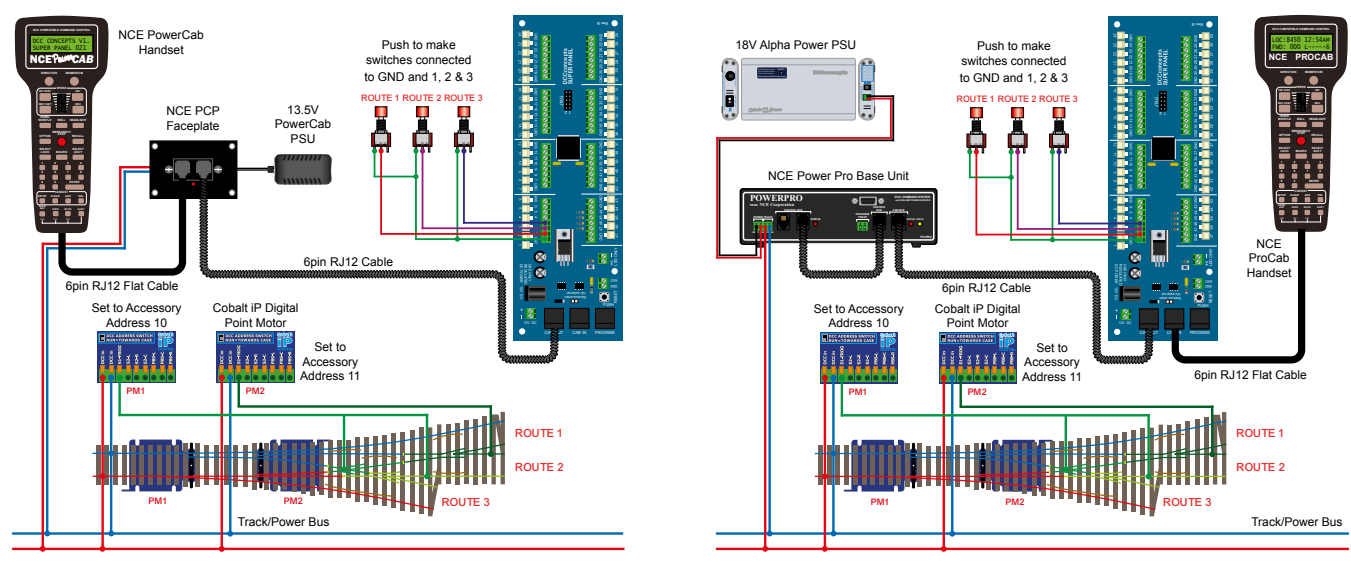

Once you become familiar with programming the Super Panel you may find it easier to write out the commands in tabular form so that you can check your logic. This can then be used to input commands to the Super Panel quickly through the NCE keypad - see the next page for the keystrokes tables for **SAMPLE 4**.

Keystroke table for Input 1:

Input No 1			
Select the Input to Input 1		1, 1, 1, ENTER, 1, ENTER	
Step	Keystrokes	LOW Action	HIGH Action
1	1, 10, ENTER, 1, ENTER	Accessory 10 Normal	<i>Not Needed</i>
2	1, 11, ENTER, 1, ENTER	Accessory 11 Normal	<i>Not Needed</i>
3	0, ENTER	End	<i>Not Needed</i>

Keystroke table for Input 2:

Input No 2			
Select the Input to Input 2		1, 1, 2, ENTER, 1, ENTER	
Step	Keystrokes	LOW Action	HIGH Action
1	1, 10, ENTER, 1, ENTER	Accessory 10 Normal	<i>Not Needed</i>
2	1, 11, ENTER, 2, ENTER	Accessory 11 Reverse	<i>Not Needed</i>
3	0, Enter	End	<i>Not Needed</i>

Keystroke table for Input 3:

Input No 3			
Select the Input to Input 3		1, 1, 3, ENTER, 1, ENTER	
Step	Keystrokes	LOW Action	HIGH Action
1	1, 10, ENTER, 2, ENTER	Accessory 10 Reverse	<i>Not Needed</i>
2	1, 11, ENTER, 2, ENTER	Accessory 11 Reverse	<i>Not Needed</i>
3	0, Enter	End	<i>Not Needed</i>

Please note: These command streams use the **ENTER** key instead of the **ADD** key as there are no commands in the **HIGH** column, only commands in the **LOW** commands.

See the bottom of Page 39 - 7.1 ACCY - 1 = Accessory Number in the full Super Panel User Guide for more information on this.

Sample 4 - Layout Concepts Parts List

Qty	Part No.	Description
1 x	DCC-SPL	Super Panel Control Board
1 x	DCD-APB	Alpha Push-Button 6-Pack of Push-Button Switches
2 x	DCP-CB1DiP	Cobalt iP Digital Point Motor Single Pack
2 x	DCD-ACL	RJ12 6pin Curly Cord For NCE Powercab and Cobalt Alpha
1 x	Three-Way Point - various makes can be used	

Various cable and connectors

Don't forget, you will also need an NCE system, either a PowerCab or PowerPro, to be able to program and run the Super Panel.

You have now configured your Super Panel to control a three way point motor from three separate push to make switches.

To control further switches and point motors you just repeat this process, making sure you select the correct input to the Super Panel and the correct digital address for the accessory.

Sample 5

Connecting a Cobalt S-Lever To Super Panel

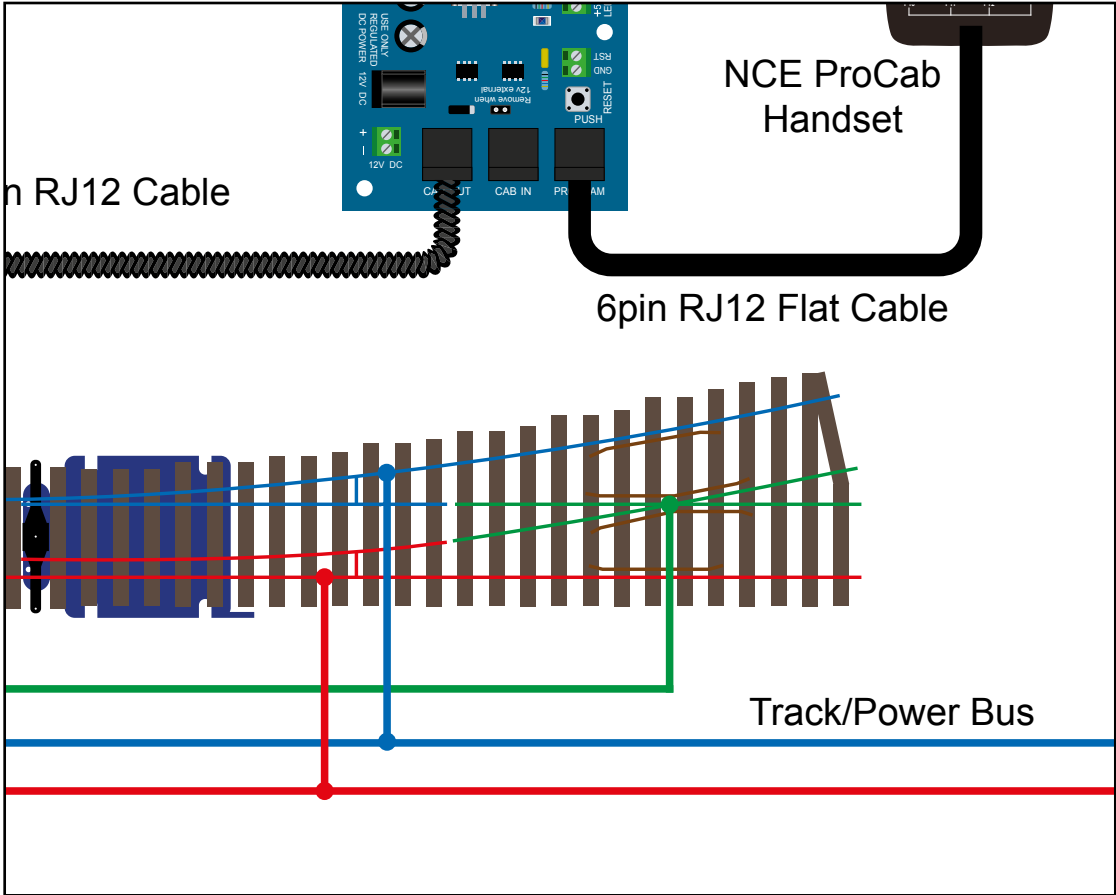

Connecting A Cobalt S-Lever To Super Panel

Sample 5

PowerCab Programming Set Up

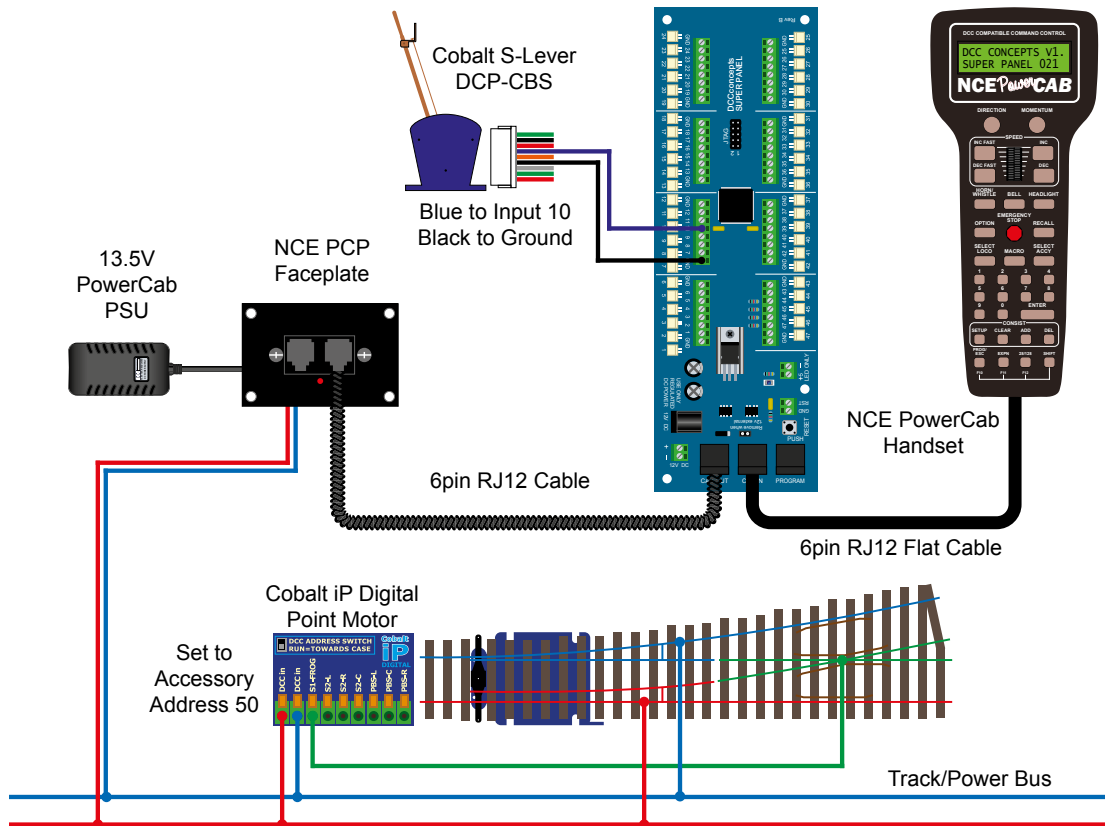

Power Pro Programming Set Up

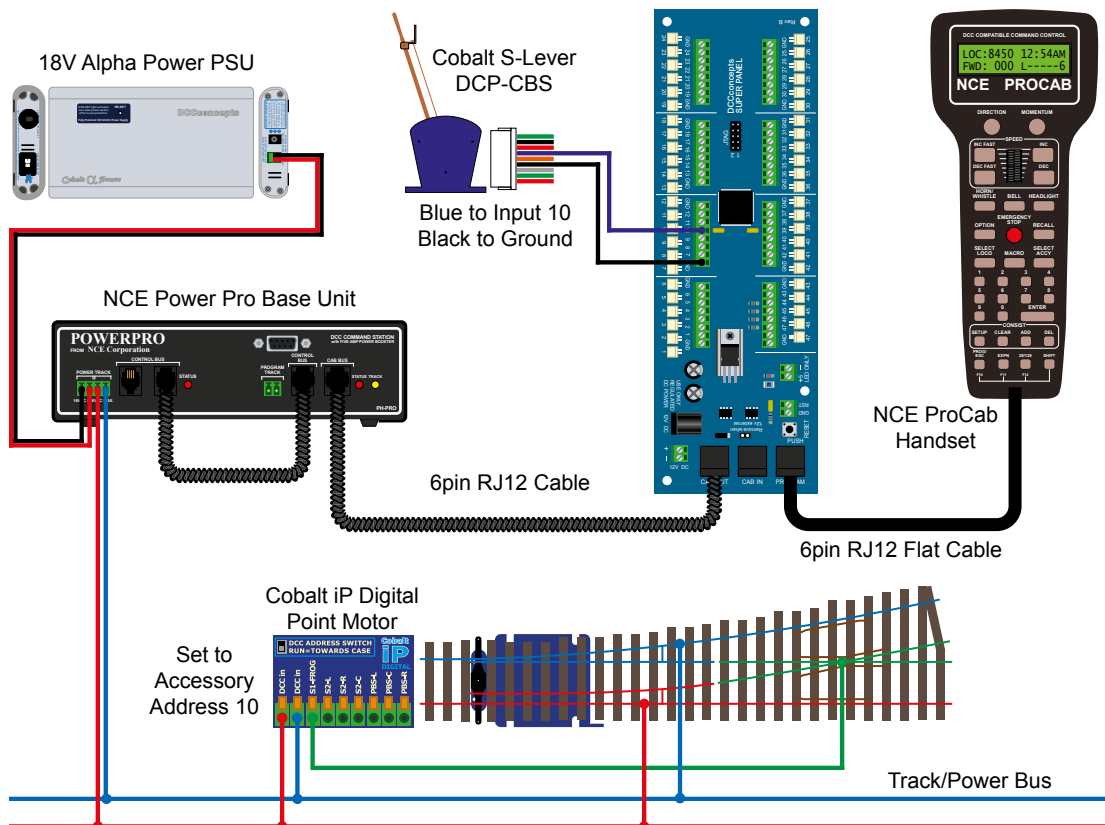

When using a Cobalt S-Lever with the Super Panel, we are going to use the changeover connections on the S-Lever. So, from the middle of the wiring harness, connected the **BLACK** cable to the **GROUND** and the **BLUE** cable to the desired **INPUT**. See the diagram above for more details.

From here we program the Super-Panel in the same way as an **ON-OFF Toggle Switch** as per **SAMPLE 1**.

To match the movement of the S-Lever to the movement of the accessory, i.e. a signal, just swap the **N/1** or **R/2** direction in the **INPUT STEP** programming for the required step.

Before you can run your program from the SuperPanel you need to reconnect the NCE system to the appropriate input on either the Super Panel or your faceplate. If you have two NCE PowerCab or ProCab handsets you can leave one handset connected to the faceplate or CAB BUS and one to the PROGRAM port at all times, saving you from unplugging an plugging constantly.

PowerCab Run Set Up

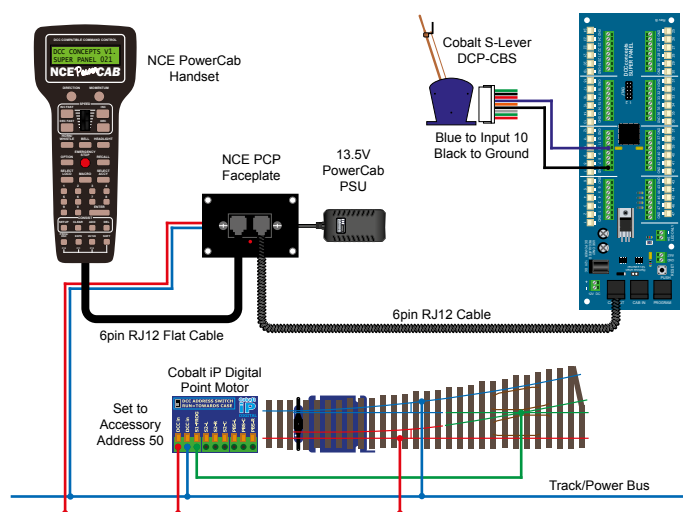

Power Pro Run Set Up

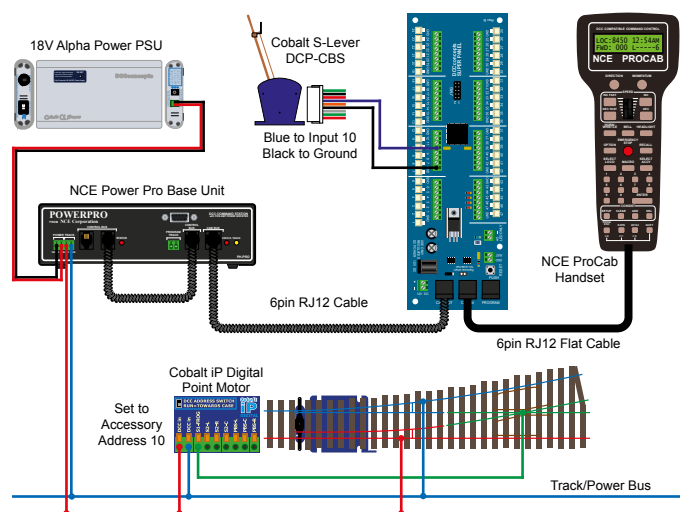

Once you become familiar with programming the Super Panel you may find it easier to write out the commands in tabular form so that you can check your logic. This can then be used to input commands to the Super Panel quickly through the NCE keypad - see below for the keystrokes table for **SAMPLE 5**.

Input No 10			
Select the Input to Input 10		1, 10, ENTER, 1, ENTER	
Step	Keystrokes	LOW Action	HIGH Action
1	1, 10, ENTER, 1, ADD	Accessory 10 Normal	Accessory 10 Reverse
2	0, ADD	End	End

Please note: This command stream use the **ADD** key instead of the **ENTER** key to duplicate the opposite action in the **HIGH** column when entering data in the **LOW** column, or vice versa.

See the bottom of Page 39 - 7.1 ACCY - 1 = Accessory Number in the full Super Panel User Guide for more information on how to achieve this.

Sample 5 - Layout Concepts Parts List

Qty	Part No.	Description
1 x	DCC-SPL	Super Panel Control Board
1 x	DCP-CBS	Cobalt S-Lever
1 x	DCP-CB1DiP	Cobalt iP Digital Point Motor Single Pack
2 x	DCD-ACL	RJ12 6pin Curly Cord For NCE Powercab and Cobalt Alpha
1 x		Left or Right hand point - various makes can be used

Various cable and connectors

Don't forget, you will also need an NCE system, either a PowerCab or PowerPro, to be able to program and run the Super Panel.

You have now configured your Super Panel to control a three way point motor from three separate push to make switches.

To control further S-Levers and point motors you just repeat this process, making sure you select the correct input to the Super Panel and the correct digital address for the accessory.

Sample 6

Connecting Alpha Switch-i To Super Panel & Alpha Mimic

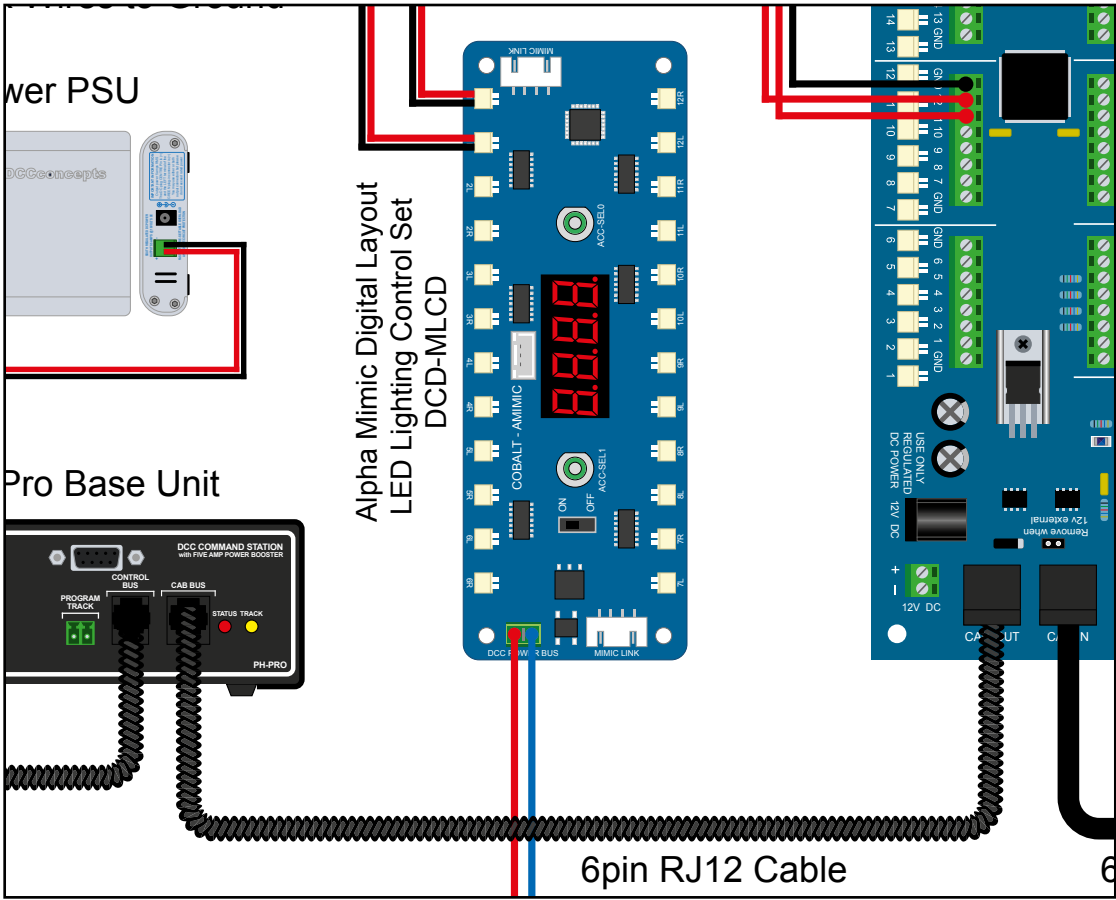

Connecting Alpha Switch-i To Super Panel & Alpha Mimic

Sample 6

PowerCab Programming Set Up

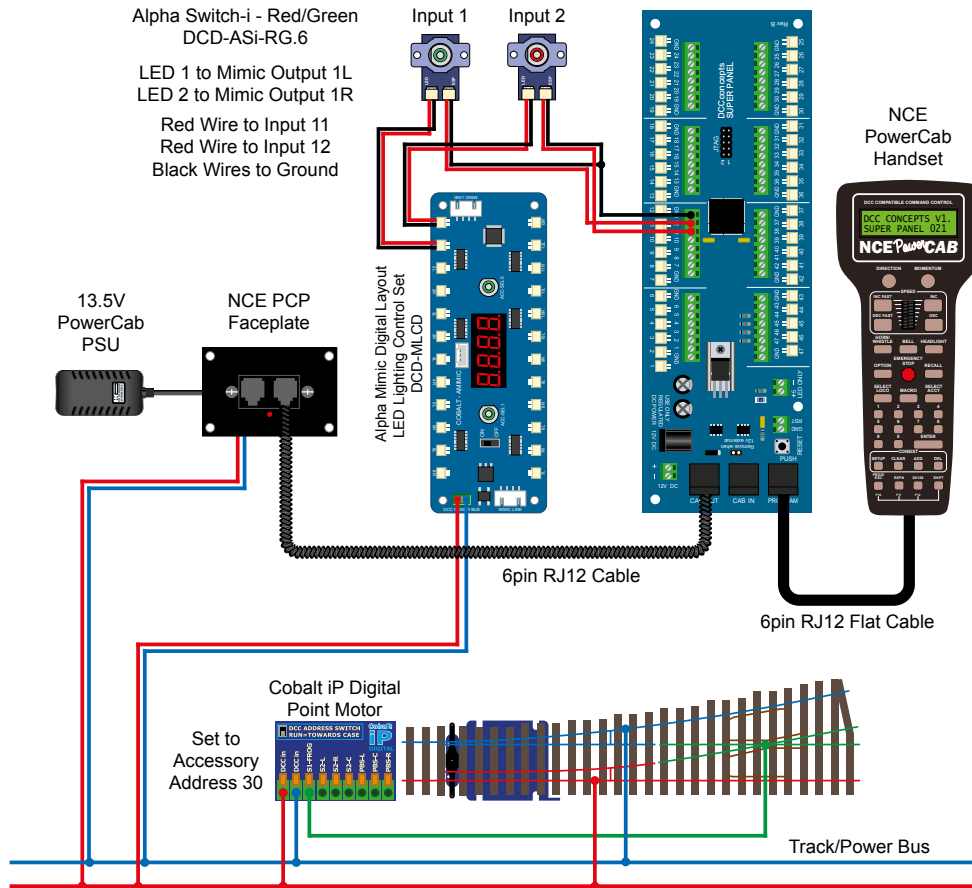

Power Pro Programming Set Up

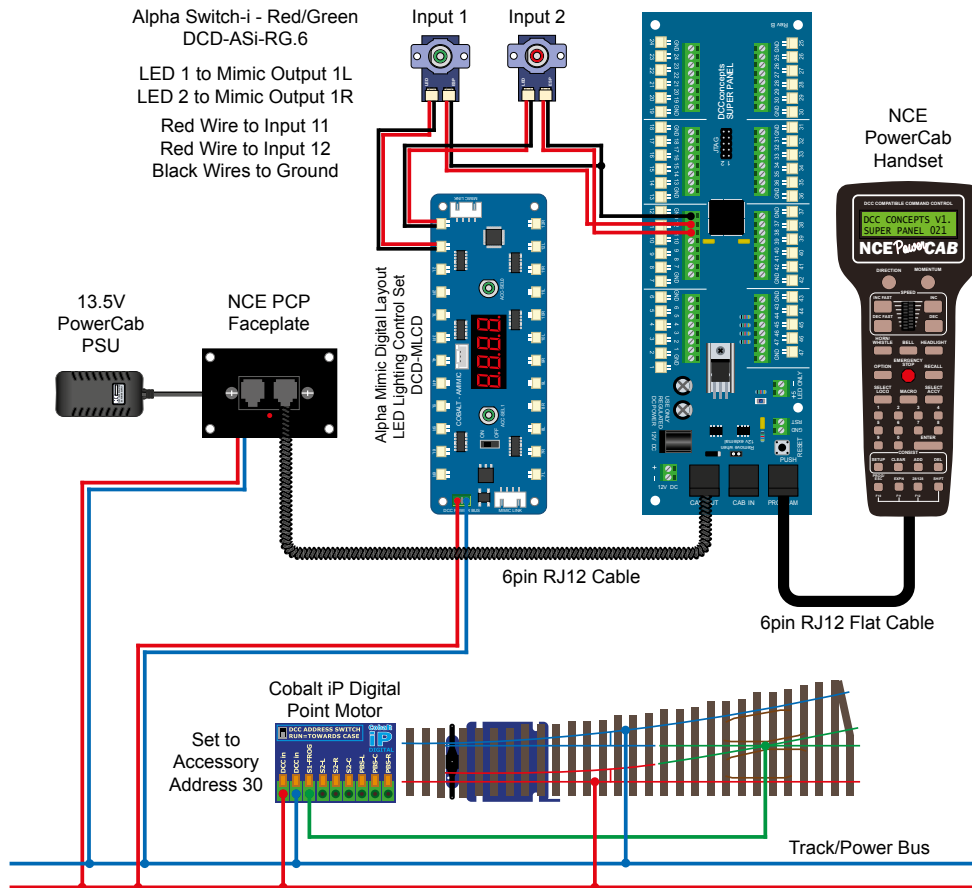

When connecting the Alpha Switch-i to the Super Panel you need to use two switches, one for each direction of the point motor. The **BLACK** switch connection is connecting to the **GROUND** on the Super-Panel and the **RED** to the required **INPUTS** - in this case, 11 and 12.

The incorporated LEDs on the switches are controlled and powered by the **Alpha Mimic Board**. The output address from the Alpha Mimic is set to match the **ACCESSORY NUMBER** of the defined device on the SUPER PANEL input

To match the movement of the Alpha Switch-i to the movement of the accessory, i.e. a point motor, just swap the **N/1** or **R/2** direction in the **INPUT STEP** programming for the required step, or swap the red connections to the **INPUT** on the Super Panel.

We will look in more detail at controlling the Alpha Mimic Panel in a future manual. It can be used to do some fun things, for example controlling street lights and engine shed lights on a timed sequence.

Step 1

Connect everything as per the above diagram and the **START SCREEN** will appear, press **ENTER** to move to the **Main Menu**:

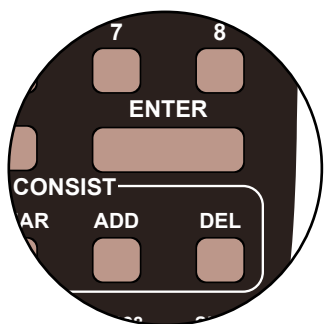

Start Screen

DCC CONCEPTS V1.
SUPER PANEL 025B

Press

ENTER

1=SETUP 2=REVIEW
3=TEST OPERATION

Step 2

Select **1=SETUP** by pressing **1**, and then **1=SET INPUT** by pressing **1**:

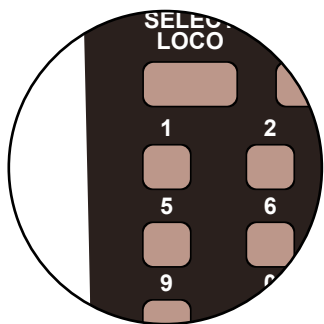

Press

1

Then Press

1

1=SETUP INPUT
2=SETUP CONFIG

SETUP INPUT MENU
INPUT:1 LO/HI:L

Step 3

As the Alpha Switch-i is a push to make switch, it can only be configured in **LOW** or **ON**, so leave the **LO/HI** at **L**. Next select **INPUT:11**, the Super Panel input you have connected the switched terminal from the Alpha Switch-i to, by pressing **1** then **1** and **ENTER**, and then select **STEP:1** by pressing **ENTER**:

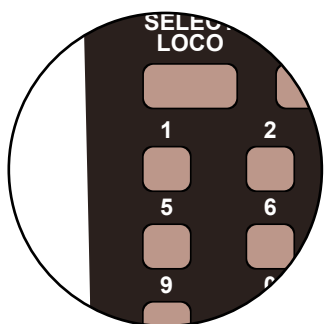

Press

1

Then Press

1

Then Press

ENTER

Then Press

ENTER

INPUT:11 LOW
STEP: 1

INP:11 L STEP:1
1=ACCY 2=MACRO >

Step 4

We have to tell the Super Panel what the device we are controlling from **INPUT 11** is. The point motor is an accessory so press **1**, then confirm the accessory number, **30**, of the motor by pressing **3** then **0** and **ENTER**.

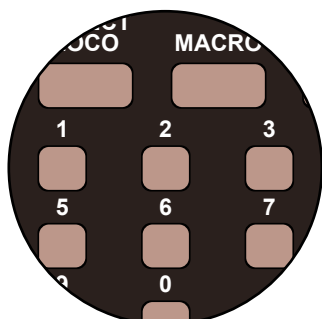

Press
1
 Then Press
3
 Then Press
0
 Then Press
ENTER

```
INP:11 L STEP:1
ACCY NUMBER:30
```

```
INP:11 L STEP:1
NORM/REV : N/1
```

Step 5

We next program the direction of the point motor, either **N/1** - straight or **R/2** - switched. This is done by using the **DIRECTION** key. We want **N/1**, so leave the settings as show on the screen and then **ENTER** to finish these settings.

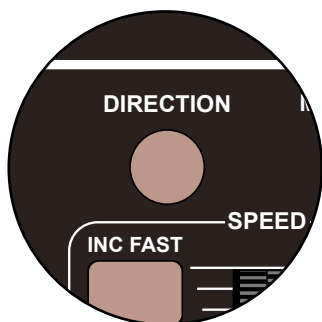

Press
DIRECTION
 THEN
 Press
ENTER

```
INP:11 L STEP:1
NORM/REV : N/1
```

```
INP:11 L STEP:2
1=ACCY 2=MACRO >
```

Step 6

We next need to tell the Alpha Mimic Panel to change the required LED to show the direction of the point on our control panel. We do this by sending a second accessory command using the required LED output on the Alpha Mimic Panel, in this case **1**. So press **1** for an accessory, and enter **0** and **1** to select accessory address 1 on the Alpha Mimic Panel and press **ENTER**.

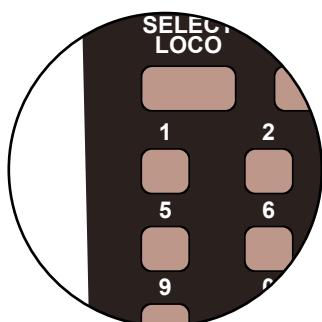

Press
1
 Then Press
0
 Then Press
1
 Then Press
ENTER

```
INP:11 L STEP:2
ACCY NUMBER:01
```

```
INP:11 L STEP:1
NORM/REV : N/1
```

Step 7

We next program the direction or in this case the colour of the LED on the Alpha Mimic Board, either **N/1 - GREEN** or **R/2 - RED**. This is done by using the **DIRECTION** key. We want **N/1**, so leave the settings as show on the screen and then **ENTER** to finish these settings.

Note - as the Alpha Switch-i switches are dual colour, the other switch will be showing the opposite colour to what you have selected in Step 2 of this command. If they are showing the wrong colour, change the direction of the command from **N/1** to **R/2** or vice versa using the **DIRECTION** key.



Press
DIRECTION
THEN
Press
ENTER

```
INP:11 L STEP:1  
NORM/REV : N/1
```

```
INP:11 L STEP:2  
1=ACCY 2=MACRO >
```

Step 8

We always finish the command line with an **END** command, then the Super Panel knows it has reached the end of this particular sequence. So press **0** to select **END** and press **ENTER**. Push the **PROG/ESC** key 2 times to return to the **SET INPUT MENU SCREEN**

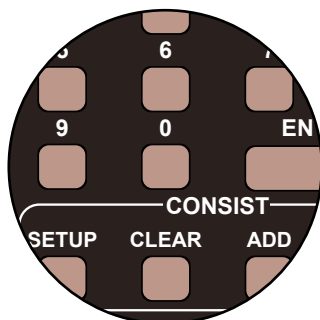

Press
0
THEN
Press
ENTER

```
INP:11 L STEP:3  
END: PRESS ENTER
```

```
INP:11 L STEP:4  
1=ACCY 2=MACRO >
```

Press **ENTER**. Push the **PROG/ESC** key 2 times to return to the **SET INPUT MENU SCREEN**

Step 9

We need to enter the command structure for the second Alpha Switch-i. So from the **SETUP INPUT MENU** enter 12 by pressing **1** and then **2**, and then press **ENTER** to select the input the Alpha Switch-i is connected to.

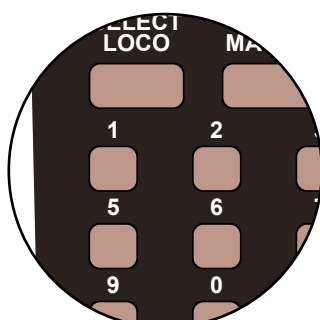

Press
1
Then Press
2
Then Press
ENTER

```
SETUP INPUT MENU  
INPUT:11 LO/HI:L
```

```
INPUT:12 LOW  
STEP: 1
```

Step 10

As the Alpha Switch-i is a push to make switch, it can only be configured in **LOW** or **ON**, so leave the **LO/Hi** at **L**. Select **STEP:1** by pressing **ENTER**, and push **1** to select an accessory.

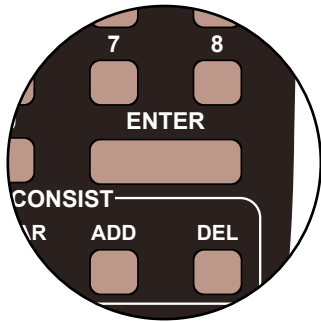

Press
ENTER
Then Press
1

```
INP:12 L STEP:1  
1=ACCY 2=MACRO >
```

```
INP:12 L STEP:1  
ACCY NUMBER:1
```

Step 11

We have to tell the Super Panel what the device we are controlling from **INPUT 12** is, which is a point motor, so confirm the accessory number, **30**, of the motor by pressing **3** then **0** and **ENTER**.

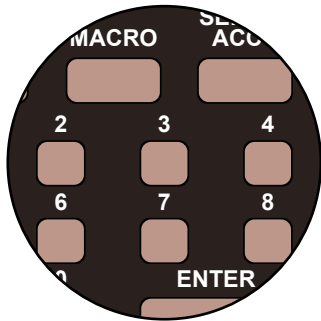

Press
3
Then Press
0
Then Press
ENTER

```
INP:12 L STEP:1  
ACCY NUMBER:30
```

```
INP:12 L STEP:1  
NORM/REV : N/1
```

Step 12

We need to program the direction of the point motor. We want the opposite direction from Input 11, which was **N/1** so push the **DIRECTION** and select **R/2** - switched, and press **ENTER** to finish these settings.



Press
DIRECTION
THEN
Press
ENTER

```
INP:12 L STEP:1  
NORM/REV : R/2
```

```
INP:12 L STEP:2  
1=ACCY 2=MACRO >
```

Step 13

We next need to tell the Alpha Mimic Panel to change the required LED to show the direction of the point on our control panel. Press **1** for an accessory, and enter **0** and **1** to select accessory address 1 on the Alpha Mimic Panel and press **ENTER**.

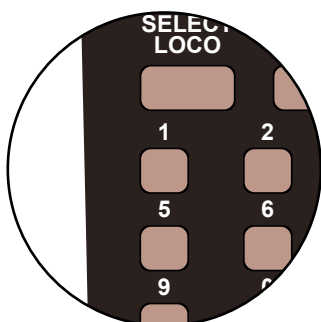

Press
1
Then Press
0
Then Press
1
Then Press
ENTER

```
INP:12 L STEP:2  
ACCY NUMBER:01
```

```
INP:12 L STEP:2  
NORM/REV : R/2
```

Step 14

We next program the direction or in this case the colour of the LED on the Alpha Mimic Board, either **N/1 - GREEN** or **R/2 - RED**. This is done by using the **DIRECTION** key. We want **R/2**, so leave the settings as show on the screen and then **ENTER** to finish these settings.

Note - as the Alpha Switch-i switches are dual colour, the other switch will be showing the opposite colour to what you have selected in Step 2 of this command. If they are showing the wrong colour, change the direction of the command from **N/1** to **R/2** or vice versa using the **DIRECTION** key.

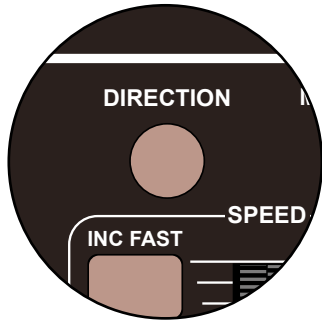

Press
DIRECTION
THEN
Press
ENTER

```
INP:12 L STEP:2
NORM/REV : R/2
```

```
INP:12 L STEP:3
1=ACCY 2=MACRO >
```

Step 15

We always finish the command line with an **END** command, then the Super Panel knows it has reached the end of this particular sequence. So press **0** to select **END** and press **ENTER**. Push the **PROG/ESC** key 2 times to return to the **SET INPUT MENU SCREEN**

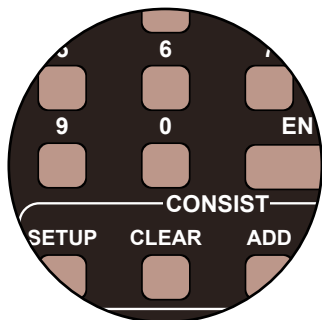

Press
0
THEN
Press
ENTER

```
INP:12 L STEP:3
END: PRESS ENTER
```

```
INP:12 L STEP:4
1=ACCY 2=MACRO >
```

Press **ENTER**. Push the **PROG/ESC** key 2 times to return to the **SET INPUT MENU SCREEN**

Before you can run your program from the SuperPanel you need to reconnect the NCE system to the appropriate input on either the Super Panel or your faceplate. If you have two NCE PowerCab or ProCab handsets you can leave one handset connected to the faceplate or CAB BUS and one to the PROGRAM port at all times, saving you from unplugging an plugging constantly.

PowerCab Run Set Up

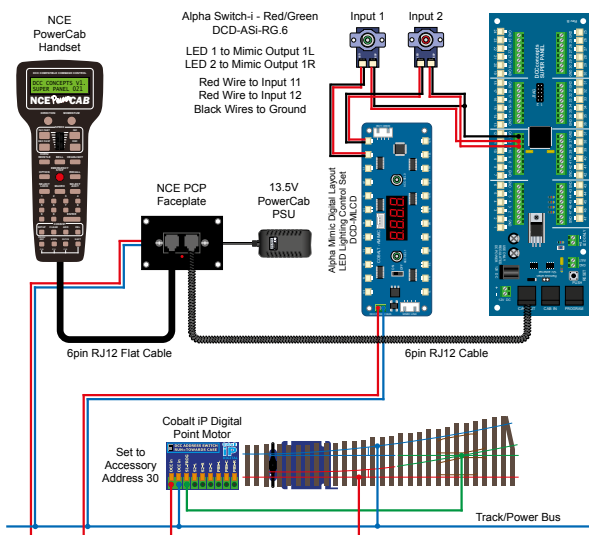

Power Pro Run Set Up

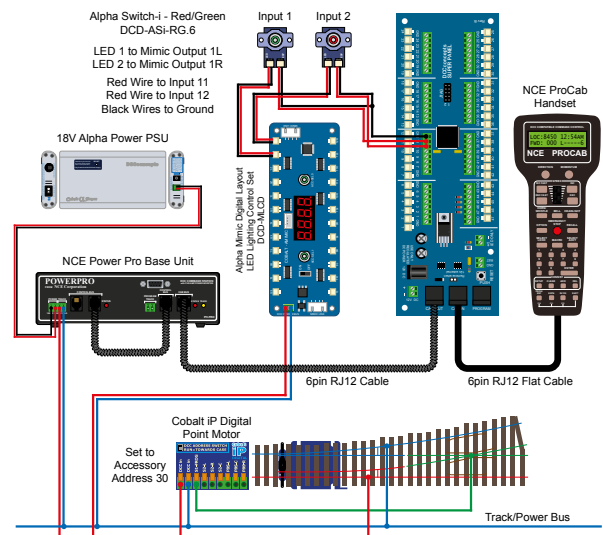

Once you become familiar with programming the Super Panel you may find it easier to write out the commands in tabular form so that you can check your logic. This can then be used to input commands to the Super Panel quickly through the NCE keypad - see below for the keystrokes table for **SAMPLE 6**.

Keystroke table for Input 11:

Input No 11			
Select the Input to Input 11		1, 11, ENTER, 1, ENTER	
Step	Keystrokes	LOW Action	HIGH Action
1	1, 30, ENTER, 1, ENTER	Accessory 30 Normal	<i>Not needed</i>
2	1, 0, 1, ENTER, 1, ENTER	Accessory 1 Normal	<i>Not needed</i>
3	0, ENTER	End	<i>Not needed</i>

Keystroke table for Input 12:

Input No 12			
Select the Input to Input 12		1, 12, ENTER, 1, ENTER	
Step	Keystrokes	LOW Action	HIGH Action
1	1, 30, ENTER, 2, ENTER	Accessory 30 Reverse	<i>Not needed</i>
2	1, 0, 1, ENTER, 2, ENTER	Accessory 1 Reverse	<i>Not needed</i>
3	0, ENTER	End	<i>Not needed</i>

Please note: These command streams use the **ENTER** key instead of the **ADD** key as there are no commands in the **HIGH** column, only commands in the **LOW** commands.

See the bottom of Page 39 - 7.1 ACCY - 1 = Accessory Number in the full Super Panel User Guide for more information on this.

You have now configured your Super Panel to control a way point motor from two Alpha Switch-i push buttons.

To control further Alpha Switch-i switches and point motors you just repeat this process, making sure you select the correct input to the Super Panel and the correct digital address for the accessory.

Sample 6 - Layout Concepts Parts List

Qty	Part No.	Description
1 x	DCC-SPL	Super Panel Control Board
1 x	DCD-ASi-RG.6	Alpha Switch-i Red/Green 6 Pack
1 x	DCD-MLCD	Alpha Mimic Digital Layout LED Lighting Control Set
1 x	DCP-CB1DiP	Cobalt iP Digital Point Motor Single Pack
1 x		Left or Right hand point - various makes can be used

Various cable and connectors

Don't forget, you will also need an NCE system, either a PowerCab or PowerPro, to be able to program and run the Super Panel.

Sample 7

Route Setting With 3 Point Motors, 4 Push Buttons and A Super Panel

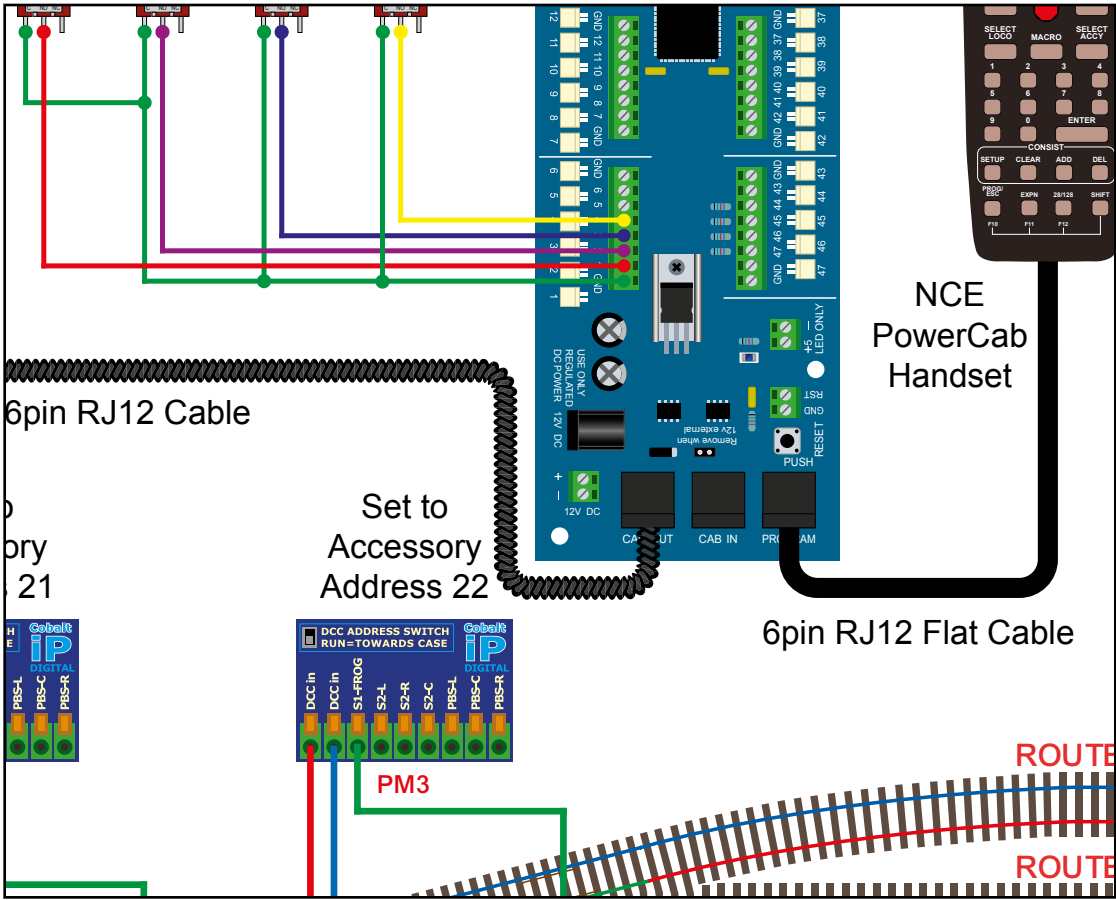

Route Setting With 3 Point Motors, 4 Push Buttons and A Super Panel

Sample 7

PowerCab Programming Set Up

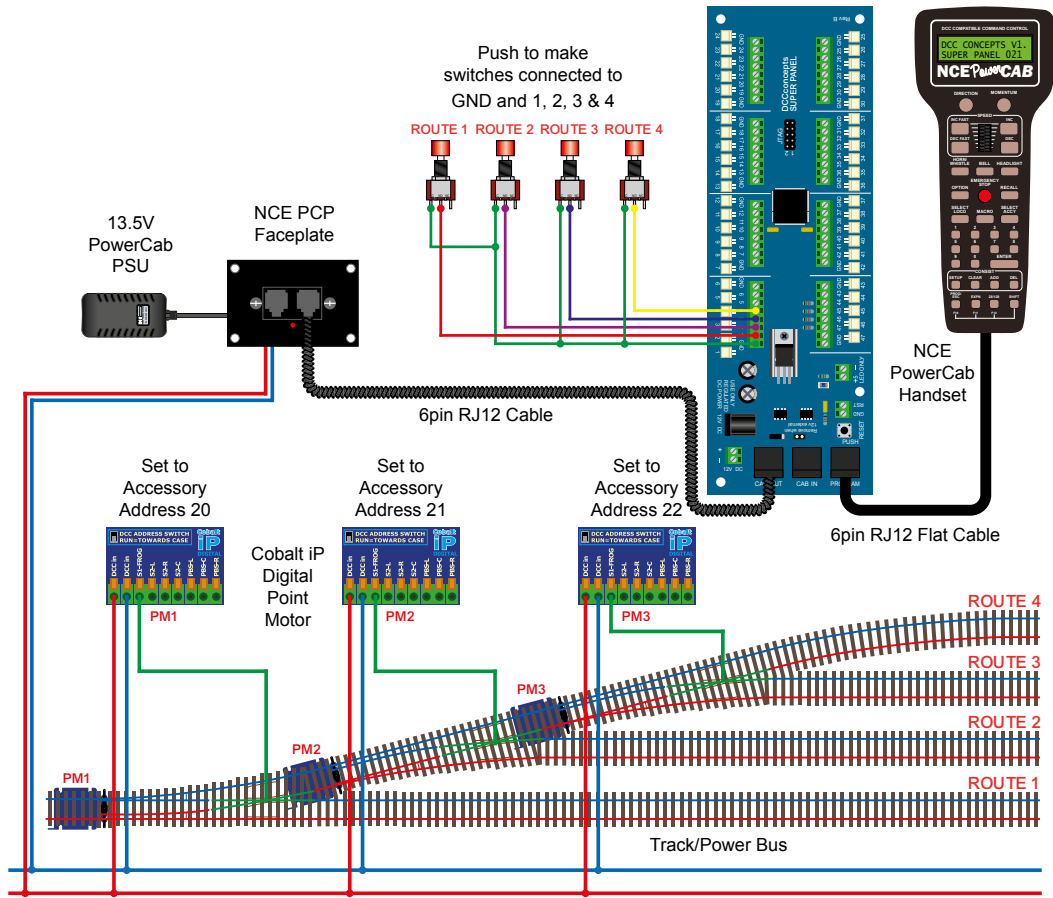

Power Pro Programming Set Up

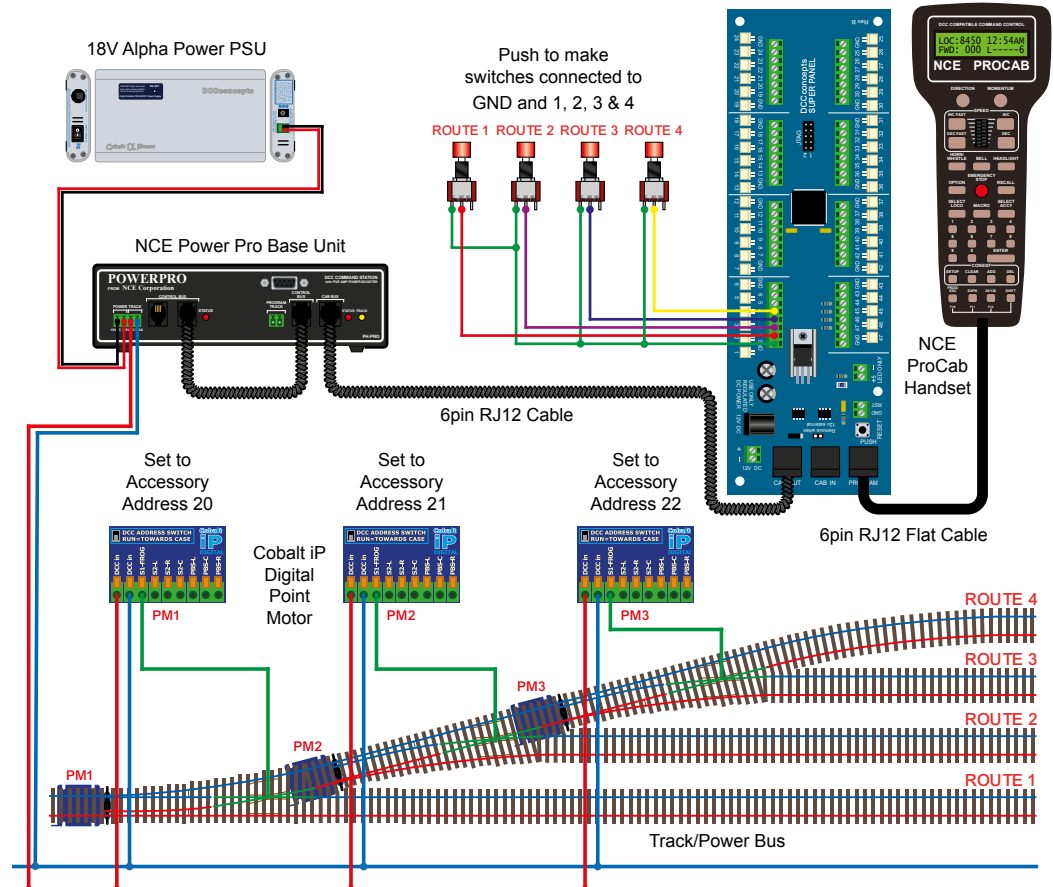

The Super Panel comes into its own when you need to control multiple accessories with one switch. A classic model railway example is route setting for a storage yard.

In the diagram above you can see we have 4 push to make switches used to select 4 different routes. Each route is selected via 3 point motors - hence push one button and the Super Panel changes the required motors to the route selected.

Before we start programming the Super Panel we need to work out a logic table for the direction of each point motor with each button push to each required route. It would not be difficult to add LED indication to a control panel as well, but more on that in a later guide.

The table below allows us to see exactly the position of each point before we start programming. If you had a large storage yard with many more points and switches, creating the table first will speed up the programming process on the Super Panel.

	Point Motor Position		
Route	Point Motor 1	Point Motor 2	Point Motor 3
Acc Number	20	21	22
Route 1	<i>Normal</i>	<i>N/A</i>	<i>N/A</i>
Route 2	<i>Reversed</i>	<i>Reversed</i>	<i>N/A</i>
Route 3	<i>Reversed</i>	<i>Normal</i>	<i>Reversed</i>
Route 4	<i>Reversed</i>	<i>Normal</i>	<i>Normal</i>

We will program each push button, one at a time.

Step 1

First we need to set **Route 1** - so setting **Point Motor 1**, first, we connect everything as per the diagram and the **START SCREEN** will appear, press **ENTER** to move to the **Main Menu**:

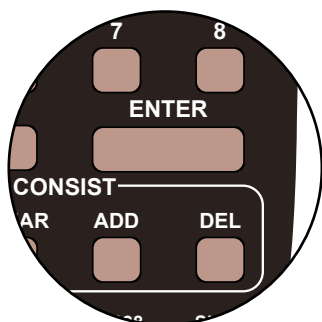

Start Screen

Press



DCC CONCEPTS V1.
SUPER PANEL 025B

1=SETUP 2=REVIEW
3=TEST OPERATION

Step 2

Select **1=SETUP** by pressing **1**, and then **1=SET INPUT** by pressing **1**:

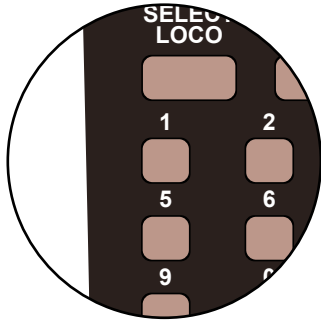

Press

1

THEN

Press

1

```
1=SETUP INPUT
2=SETUP CONFIG
```

```
SETUP INPUT MENU
INPUT:1 LO/HI:L
```

Step 3

Set **INPUT:1** push to make switch to **LOW**, by pressing **DIRECTION** and **ENTER**, and then select **STEP:1** by pressing **ENTER**:

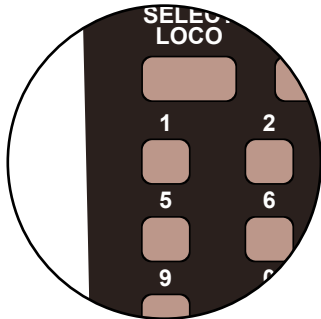

Press

1

THEN

ENTER

Press

ENTER

```
INPUT:1 LOW
STEP: 1
```

```
INP:1 L STEP:1
1=ACCY 2=MACRO >
```

Step 4

The point motor is an accessory so press **1**, then confirm the accessory number, **20**, of the motor by pressing **2** then **0** and **ENTER**.

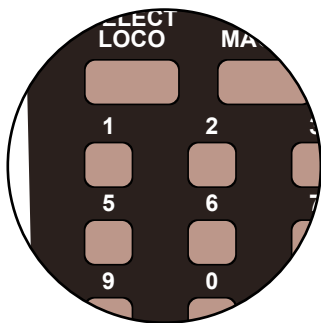

Press

1

Then Press

2

Then Press

0

Then Press

ENTER

```
INP:1 L STEP:1
ACCY NUMBER:20
```

```
INP:1 L STEP:1
NORM/REV : N/1
```

Step 5

We want the motor to move to the **NORMAL** or **N/1** position, so leave the settings as show on the screen and **ENTER** to save these settings.

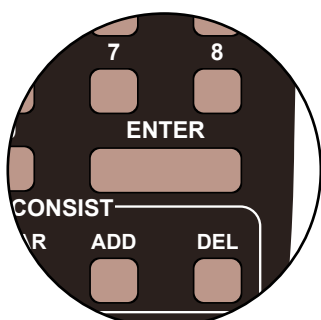

Press

ENTER

```
INP:1 L STEP:1
NORM/REV : N/1
```

```
INP:1 L STEP:2
1=ACCY 2=MACRO >
```

Step 6

We always finish the command line with an **END** command, then the Super Panel knows it has reached the end of this particular sequence. So press **0** to select **END** and press **ENTER**. Push the **PROG/ESC** key 2 times to return to the **SET INPUT MENU SCREEN**

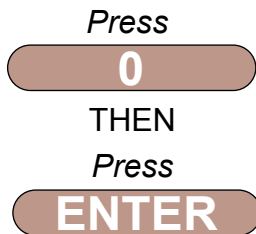
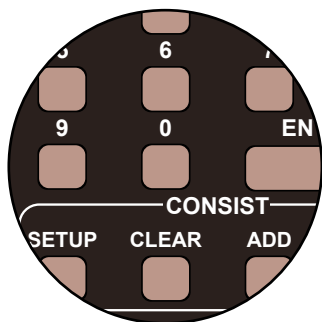

```
INP:1  L STEP:2
END: PRESS ENTER
```

```
INP:1  L STEP:3
1=ACCY 2=MACRO >
```

Press **ENTER**. Push the **PROG/ESC** key 3 times to return to the **SET INPUT MENU SCREEN**

That is the route for Push Button 1 set. We don't need to set the other point motor position for this switch as the push to make switch is only ever used to set Point Motor 20 in this one direction.

Now we will set **Route 2** - so setting **Point Motor 1** and **Point Motor 2**.

Step 7

Select **1=SETUP** by pressing **1**, and then **2=SET INPUT** by pressing **2** then press **ENTER**.

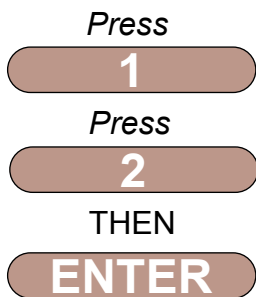
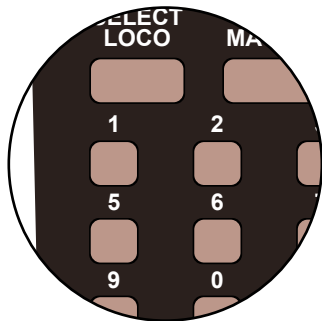

```
1=SETUP INPUT
2=SETUP CONFIG
```

```
SETUP INPUT MENU
INPUT:2  LO/HI:L
```

Step 8

Set **INPUT:2** to **LOW**, by pressing **DIRECTION**, if needed, and then select **STEP:1** by pressing **ENTER**:

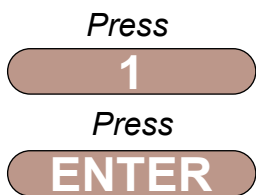
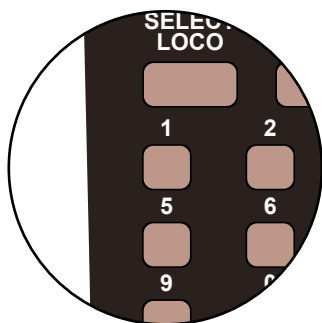

```
INPUT:2  LOW
STEP: 1
```

```
INP:1  L STEP:1
1=ACCY 2=MACRO >
```

Step 9

The point motor is an accessory so press **1**, then confirm the accessory number, **20**, of the motor by pressing **2** then **0** and **ENTER**.

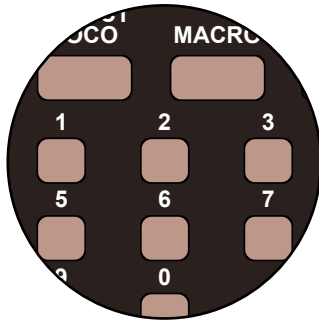

Press

1

Then Press

2

Then Press

0

Then Press

ENTER

```
INP:2 L STEP:1
ACCY NUMBER:20
```

```
INP:2 L STEP:1
NORM/REV : N/1
```

Step 10

We want the motor to move to the **REVERSE** or **R/2** position, so change the settings as show on the screen using the **DIRECTION** key and **ENTER** to save these settings.



Press

DIRECTION

THEN

Press

ENTER

```
INP:2 L STEP:1
NORM/REV : R/2
```

```
INP:2 L STEP:2
1=ACCY 2=MACRO >
```

Step 11

We now need to enter the commands for the second point motor, so it is an accessory so press **1**, then confirm the accessory number, **21**, of the motor by pressing **2** then **1** and **ENTER**.

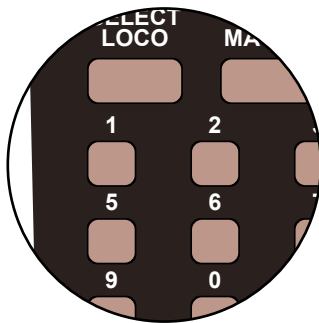

Press

1

Then Press

2

Then Press

1

Then Press

ENTER

```
INP:2 L STEP:2
ACCY NUMBER:21
```

```
INP:2 L STEP:2
NORM/REV : R/2
```

Step 12

We want the motor to move to the **REVERSE** or **R/2** position, so leave the settings as show on the screen and **ENTER** to save these settings.

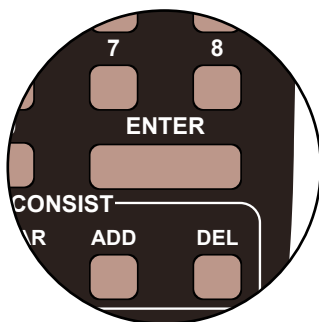

Press

ENTER

```
INP:2 L STEP:2
NORM/REV : R/2
```

```
INP:2 L STEP:3
1=ACCY 2=MACRO >
```

Step 13

We always finish the command line with an **END** command, then the Super Panel knows it has reached the end of this particular sequence. So press **0** to select **END** and press **ENTER**. Push the **PROG/ESC** key 2 times to return to the **SET INPUT MENU SCREEN**

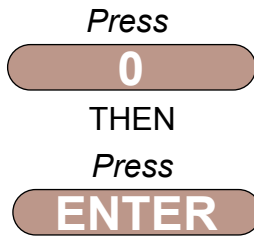
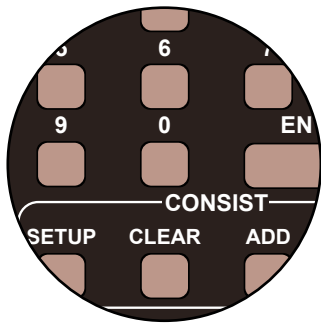

```
INP:2  L STEP:3  
END: PRESS ENTER
```

```
INP:2  L STEP:4  
1=ACCY 2=MACRO >
```

Press **ENTER**. Push the **PROG/ESC** key 3 times to return to the **SET INPUT MENU SCREEN**

That is the route for Push Button 2 set. We don't need to set anything for point motor 3's position for this switch as the push to make switch is only ever used to set Point Motors 20 and 21 in this one direction.

Now we will set **Route 3** - so setting **Point Motor 1**, **Point Motor 2** and **Point Motor 3**

Step 14

Select **1=SETUP** by pressing **1**, and then **3=SET INPUT** by pressing **3** and then **ENTER**:

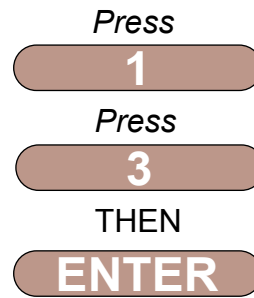
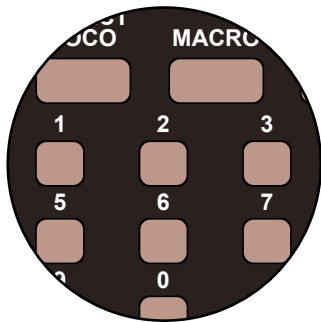

```
1=SETUP INPUT  
2=SETUP CONFIG
```

```
SETUP INPUT MENU  
INPUT:3  LO/HI:L
```

Step 15

Set **INPUT:3** to **LOW**, by pressing **DIRECTION**, if needed, and then select **STEP:1** by pressing **ENTER**:

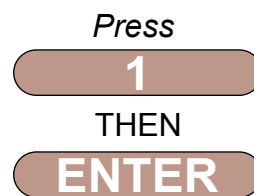
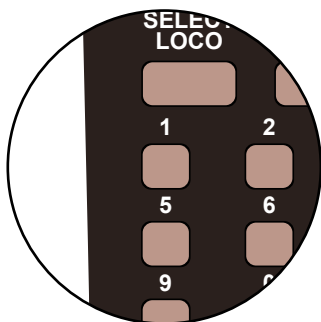

```
INPUT:3  LOW  
STEP: 1
```

```
INP:3  L STEP:1  
1=ACCY 2=MACRO >
```

Step 16

The point motor is an accessory so press **1**, then confirm the accessory number, **20**, of the motor by pressing **2** then **0** and **ENTER**.

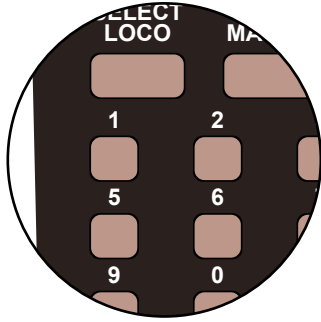

Press

1

Then Press

2

Then Press

0

Then Press

ENTER

```
INP:3  L STEP:1
ACCY NUMBER:20
```

```
INP:3  L STEP:1
NORM/REV : N/1
```

Step 17

We want the motor to move to the **REVERSE** or **R/2** position, so leave the settings as show on the screen and **ENTER** to save these settings.

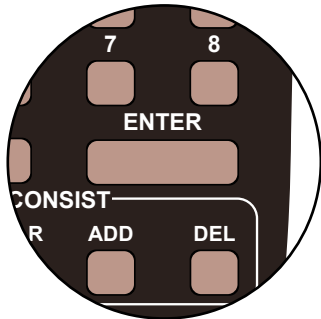

Press

ENTER

```
INP:3  L STEP:1
NORM/REV : R/2
```

```
INP:3  L STEP:2
1=ACCY 2=MACRO >
```

Step 18

We now need to enter the commands for the second point motor, so it is an accessory so press **1**, then confirm the accessory number, **21**, of the motor by pressing **2** then **1** and **ENTER**.



Press

1

Then Press

2

Then Press

1

Then Press

ENTER

```
INP:3  L STEP:2
ACCY NUMBER:21
```

```
INP:3  L STEP:2
NORM/REV : R/2
```

Step 19

We want the motor to move to the **NORMAL** or **N/1** position, so change the settings as show on the screen using the **DIRECTION** key and **ENTER** to save these settings.



Press

DIRECTION

THEN

Press

ENTER

```
INP:3  L STEP:2
NORM/REV : N/1
```

```
INP:3  L STEP:3
1=ACCY 2=MACRO >
```

Step 20

We now need to enter the commands for the third point motor, so it is an accessory so press **1**, then confirm the accessory number, **22**, of the motor by pressing **2** then **2** and **ENTER**.

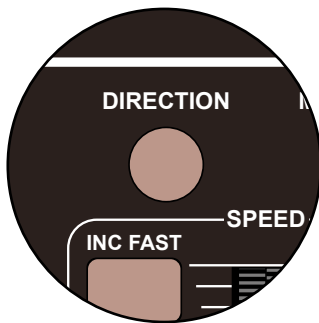

Press

1

Then Press

2

Then Press

2

Then Press

ENTER

```
INP:3  L STEP:3
ACCY NUMBER:22
```

```
INP:3  L STEP:3
NORM/REV : N/1
```

Step 21

We want the motor to move to the **REVERSE** or **R/2** position, so change the settings as show on the screen using the **DIRECTION** key and **ENTER** to save these settings.

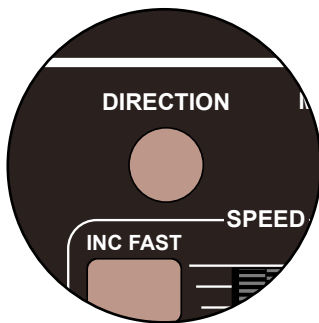

Press

DIRECTION

THEN

Press

ENTER

```
INP:3  L STEP:3
NORM/REV : R/2
```

```
INP:3  L STEP:4
1=ACCY 2=MACRO >
```

Step 22

We always finish the command line with an **END** command, then the Super Panel knows it has reached the end of this particular sequence. So press **0** to select **END** and press **ENTER**. Push the **PROG/ESC** key 2 times to return to the **SET INPUT MENU SCREEN**

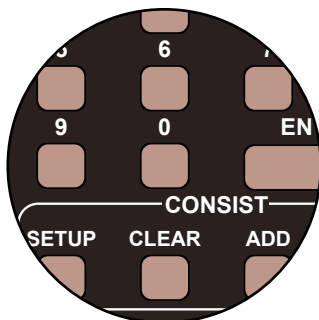

Press

0

THEN

Press

ENTER

```
INP:3  L STEP:4
END: PRESS ENTER
```

```
INP:3  L STEP:5
1=ACCY 2=MACRO >
```

Press **ENTER**. Push the **PROG/ESC** key 3 times to return to the **SET INPUT MENU SCREEN**

That is the route for Push Button 3 set. This route uses all three point motors in various positions. If you unsure of the point motor direction you can always go back to the route table at the start of the sample.

Now we will set **Route 4** - so setting **Point Motor 1**, **Point Motor 2** and **Point Motor 3**

Step 23

Select **1=SETUP** by pressing **1**, and then **4=SET INPUT** by pressing **4** and then **ENTER**:

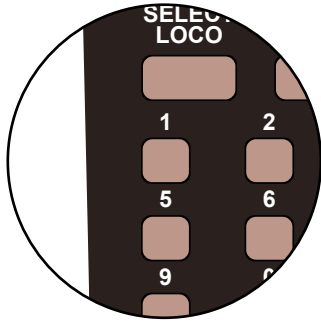

Press
1
THEN
Press
4

```
1=SETUP INPUT
2=SETUP CONFIG
```

```
SETUP INPUT MENU
INPUT:4 LO/HI:L
```

Step 24

Set **INPUT:4** to **LOW**, by pressing **DIRECTION**, if needed, and then select **STEP:1** by pressing **ENTER**:

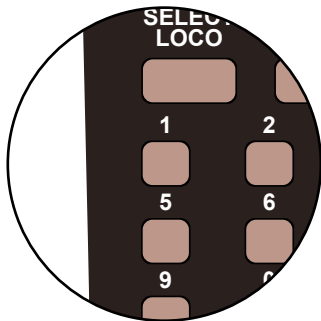

Press
1
THEN
ENTER

```
INPUT:4 LOW
STEP: 1
```

```
INP:4 L STEP:1
1=ACCY 2=MACRO >
```

Step 25

The point motor is an accessory so press **1**, then confirm the accessory number, **20**, of the motor by pressing **2** then **0** and **ENTER**.

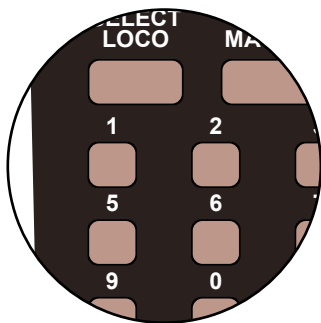

Press
1
Then Press
2
Then Press
0
Then Press
ENTER

```
INP:4 L STEP:1
ACCY NUMBER:20
```

```
INP:4 L STEP:1
NORM/REV : R/2
```

Step 26

We want the motor to move to the **REVERSE** or **R/2** position, so leave the settings as show on the screen and press **ENTER** to save these settings.



Press
ENTER

```
INP:4 L STEP:1
NORM/REV : R/2
```

```
INP:4 L STEP:2
1=ACCY 2=MACRO >
```

Step 27

We now need to enter the commands for the second point motor, so it is an accessory so press **1**, then confirm the accessory number, **21**, of the motor by pressing **2** then **1** and **ENTER**.

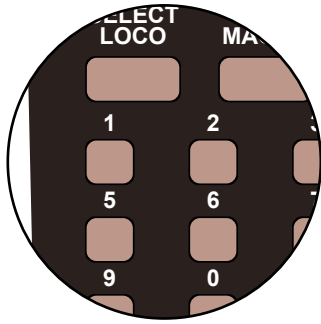

Press

1

Then Press

2

Then Press

1

Then Press

ENTER

```
INP:4  L STEP:2
ACCY NUMBER:21
```

```
INP:4  L STEP:2
NORM/REV : R/2
```

Step 28

We want the motor to move to the **REVERSE** or **R/2** position, so leave the settings as show on the screen and **ENTER** to save these settings.

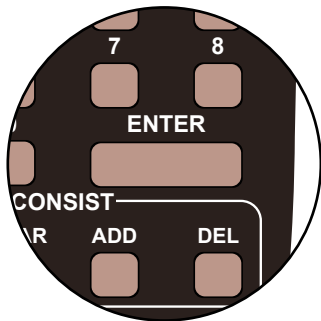

Press

ENTER

```
INP:4  L STEP:2
NORM/REV : R/2
```

```
INP:4  L STEP:3
1=ACCY 2=MACRO >
```

Step 29

We now need to enter the commands for the third point motor, so it is an accessory so press **1**, then confirm the accessory number, **22**, of the motor by pressing **2** then **2** and **ENTER**.

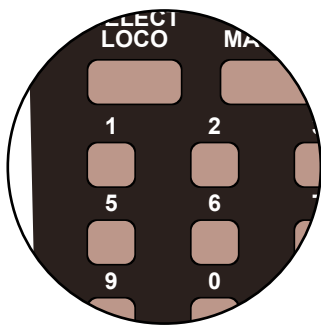

Press

1

Then Press

2

Then Press

2

Then Press

ENTER

```
INP:4  L STEP:3
ACCY NUMBER:22
```

```
INP:4  L STEP:3
NORM/REV : R/2
```

Step 30

We want the motor to move to the **NORMAL** or **N/1** position, so change the settings as show on the screen using the **DIRECTION** key and **ENTER** to save these settings.



Press

DIRECTION

THEN

Press

ENTER

```
INP:4  L STEP:3
NORM/REV : N/1
```

```
INP:4  L STEP:4
1=ACCY 2=MACRO >
```

Step 31

We always finish the command line with an **END** command, then the Super Panel knows it has reached the end of this particular sequence. So press **0** to select **END** and press **ENTER**. Push the **PROG/ESC** key 2 times to return to the **SET INPUT MENU SCREEN**

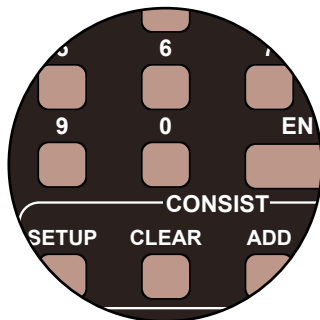

Press
0
THEN
Press
ENTER

INP:4 L STEP:4
END: PRESS ENTER

INP:4 L STEP:5
1=ACCY 2=MACRO >

Press **ENTER**. Push the **PROG/ESC** key 3 times to return to the **SET INPUT MENU SCREEN**

That is the route for Push Button 4 set. This route uses all three point motors in various positions. If you are unsure of the point motor direction you can always go back to the route table at the start of the sample.

To add further point motors and push switches you would just repeat these commands and change the appropriate Super Panel input numbers, point motor DCC accessory addresses and directions of motor travel at the relevant points.

Before you can run your program from the SuperPanel you need to reconnect the NCE system to the appropriate input on either the Super Panel or your faceplate. If you have two NCE PowerCab or ProCab handsets you can leave one handset connected to the faceplate or CAB BUS and one to the PROGRAM port at all times, saving you from unplugging and plugging constantly.

PowerCab Run Set Up

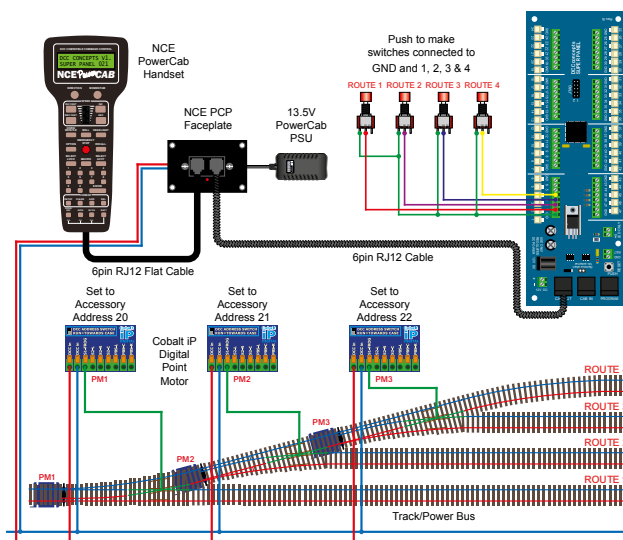

Power Pro Run Set Up

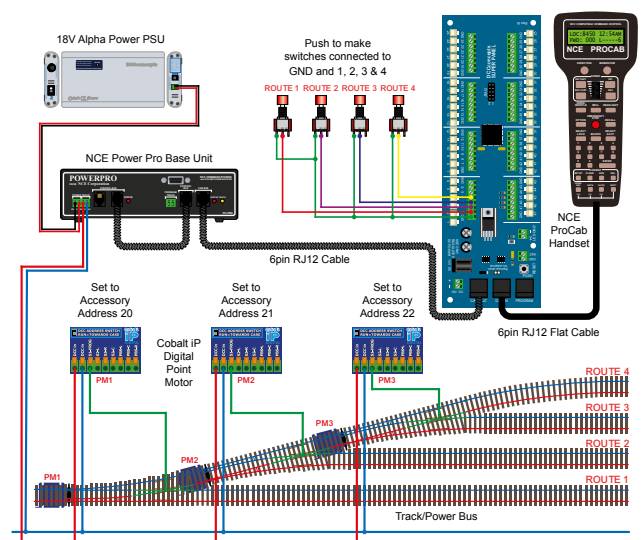

Once you become familiar with programming the Super Panel you may find it easier to write out the commands in tabular form so that you can check your logic. This can then be used to input commands to the Super Panel quickly through the NCE keypad - see below for the keystrokes table for **SAMPLE 7**.

Keystroke table for Input 1:

Input No 1			
Select the Input to Input 1		1, 1, ENTER, 1, ENTER	
Step	Keystrokes	LOW Action	HIGH Action
1	1, 20, ENTER, 1, ENTER	Accessory 20 Normal	<i>Not Needed</i>
2	0, ENTER	End	<i>Not Needed</i>

Keystroke table for Input 2:

Input No 2			
Select the Input to Input 2		1, 1, 2, ENTER, 1, ENTER	
Step	Keystrokes	LOW Action	HIGH Action
1	1, 20, ENTER, 1, ENTER	Accessory 20 Normal	<i>Not Needed</i>
2	1, 21, ENTER, 2, ENTER	Accessory 21 Reverse	<i>Not Needed</i>
3	0, ENTER	End	<i>Not Needed</i>

Keystroke table for Input 3:

Input No 3			
Select the Input to Input 3		1, 1, 3, ENTER, 1, ENTER	
Step	Keystrokes	LOW Action	HIGH Action
1	1, 20, ENTER, 2, ENTER	Accessory 20 Reverse	<i>Not Needed</i>
2	1, 21, ENTER, 1, ENTER	Accessory 21 Normal	<i>Not Needed</i>
3	1, 22, ENTER, 2, ENTER	Accessory 22 Reverse	<i>Not Needed</i>
4	0, Enter	End	<i>Not Needed</i>

Keystroke table for Input 4:

Input No 4			
Select the Input to Input 4		1, 1, 4, ENTER, 1, ENTER	
Step	Keystrokes	LOW Action	HIGH Action
1	1, 20, ENTER, 2, ENTER	Accessory 20 Reverse	Not Needed
2	1, 21, ENTER, 1, ENTER	Accessory 21 Normal	Not Needed
3	1, 22, ENTER, 1, ENTER	Accessory 22 Normal	Not Needed
2	0, Enter	End	Not Needed

Please note: These command streams use the **ENTER** key instead of the **ADD** key as there are no commands in the **HIGH** column, only commands in the **LOW** commands.

See the bottom of Page 39 - 7.1 ACCY - 1 = Accessory Number in the full Super Panel User Guide for more information on this.

Sample 7 - Layout Concepts Parts List

Qty	Part No.	Description
1 x	DCC-SPL	Super Panel Control Board
1 x	DCD-APB	Alpha Push-Button 6-Pack of Push-Button Switches
3 x	DCP-CB1DiP	Cobalt iP Digital Point Motor Single Pack
2 x	DCD-ACL	RJ12 6pin Curly Cord For NCE Powercab and Cobalt Alpha
3 x	Left or Right hand points - various makes can be used	

Various cable and connectors

Don't forget, you will also need an NCE system, either a PowerCab or PowerPro, to be able to program and run the Super Panel.

You have now configured your Super Panel to control a fiddle yard entrance using three point motors and 4 push to make switches.

Sample 8

Controlling A Double Slip Using Four Push To Make Switches

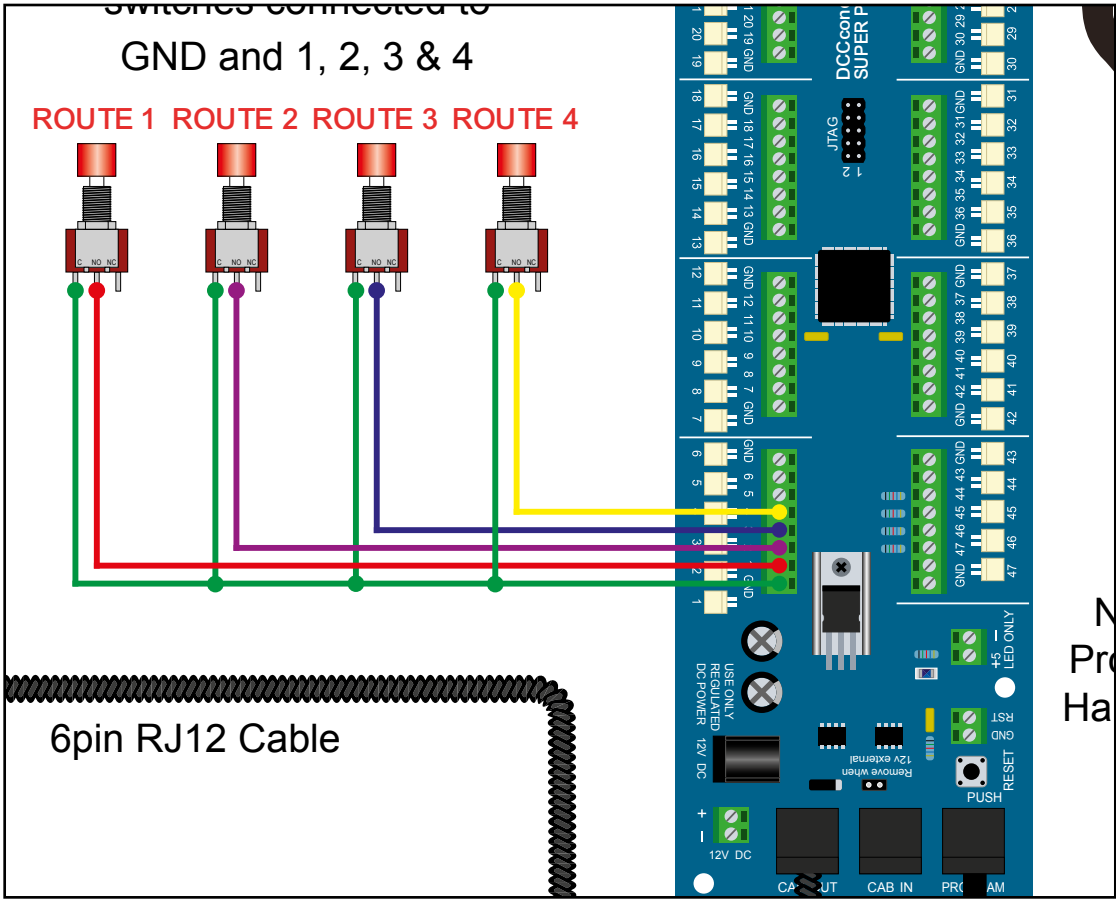

Controlling A Double Slip Using Four Push To Make Switches

Sample 8

PowerCab Programming Set Up

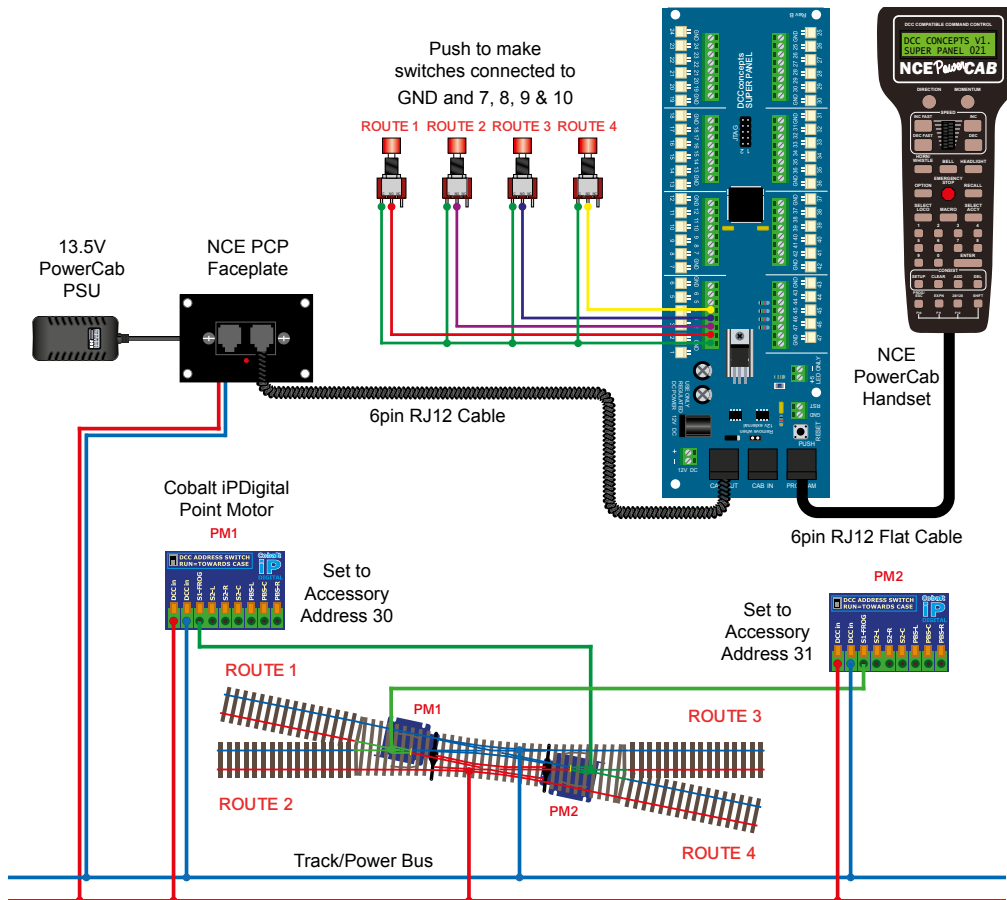

Power Pro Programming Set Up

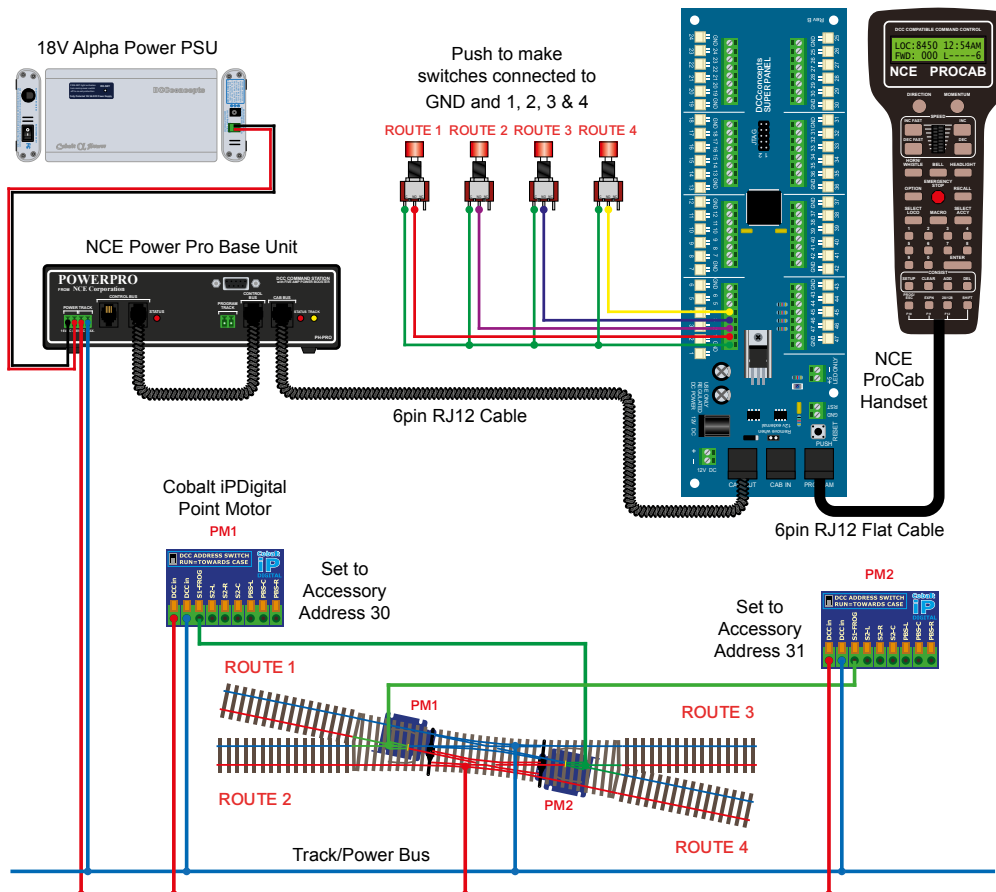

In this sample we will control a double slip with four separate push to make switches. The separate routes will be each controlled from a single push to make switch.

- To select **Route 1**, we need to set Point 1, **PM1** to **NORMAL**
- To select **Route 2**, we need to set Point 1, **PM1** to **REVERSED**
- To select **Route 3**, we need to set Point 1, **PM2** to **REVERSED**
- To select **Route 4**, we need to set Point 1, **PM2** to **NORMAL**

Step 1

First we need to set Route 1 - so setting **Point 1, PM1** first, we connect everything as per the diagram and the **START SCREEN** will appear, press **ENTER** to move to the **Main Menu**:

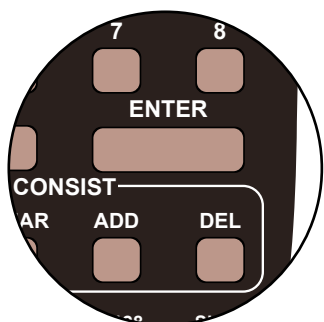

Start Screen

DCC CONCEPTS V1.
SUPER PANEL 025B

Press

ENTER

1=SETUP 2=REVIEW
3=TEST OPERATION

Step 2

Select **1=SETUP** by pressing **1**, and then **1=SET INPUT** by pressing **1**:

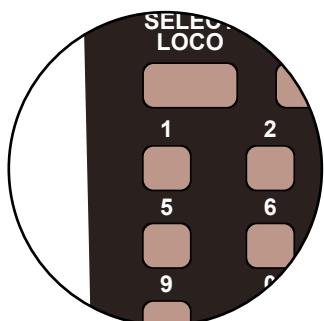

Press

1

THEN

Press

1

1=SETUP INPUT
2=SETUP CONFIG

SETUP INPUT MENU
INPUT:1 LO/HI:L

Step 3

Set **INPUT:1** push to make switch to **LOW**, by pressing **DIRECTION** and **ENTER**, and then select **STEP:1** by pressing **ENTER**:

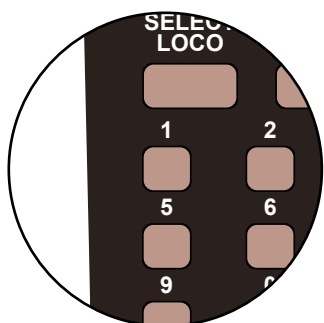

Press

1

THEN

ENTER

Press

ENTER

INPUT:1 LOW
STEP: 1

INP:1 L STEP:1
1=ACCY 2=MACRO >

Step 4

The point motor is an accessory so press **1**, then confirm the accessory number, **30**, of the motor by pressing **3** then **0** and **ENTER**.

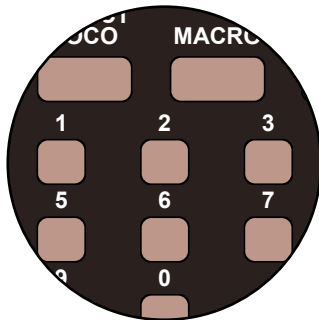

Press

1

Then Press

3

Then Press

0

Then Press

ENTER

```
INP:1  L STEP:1
ACCY NUMBER:30
```

```
INP:1  L STEP:1
NORM/REV : N/1
```

Step 5

We want the motor to move to the **NORMAL** or **N/1** position, so leave the settings as show on the screen and **ENTER** to save these settings. If needed, you can change from **N/1** to **R/2**, and vice-versa, by pushing the **DIRECTION** key.



Press

DIRECTION

THEN

Press

ENTER

```
INP:1  L STEP:1
NORM/REV : N/1
```

```
INP:1  L STEP:2
1=ACCY 2=MACRO >
```

Step 6

We always finish the command line with an **END** command, then the Super Panel knows it has reached the end of this particular sequence. So press **0** to select **END** and press **ENTER**. Push the **PROG/ESC** key 2 times to return to the **SET INPUT MENU SCREEN**

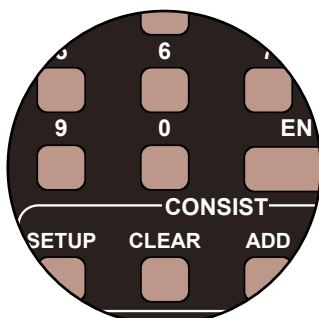

Press

0

THEN

Press

ENTER

```
INP:1  L STEP:2
END: PRESS ENTER
```

```
INP:1  L STEP:3
1=ACCY 2=MACRO >
```

Press **ENTER**. Push the **PROG/ESC** key 2 times to return to the **SET INPUT MENU SCREEN**

Step 7

Now we need to set Route 2 on **Point 1, PM1**, by pushing **2** to start the second command string.

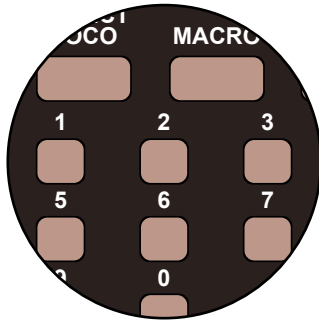

Press

2

THEN

Press

ENTER

```
SETUP INPUT MENU
INPUT:1 LO/HI:L
```

```
INPUT:2 LOW
STEP: 1
```

Step 8

The point motor is an accessory so press **1**, then confirm the accessory number, **30**, as it is still the same point motor as before we need to control, by pressing **3** then **0** and **ENTER**.

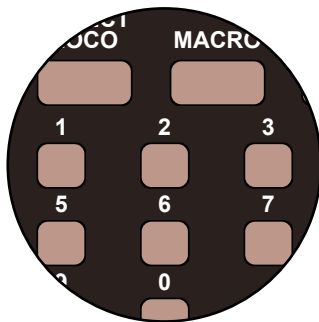

Press

1

Then Press

3

Then Press

0

Then Press

ENTER

```
INP:2 L STEP:1
ACCY NUMBER:30
```

```
INP:2 L STEP:1
NORM/REV : N/1
```

Step 9

We want the motor to move to the **REVERSE** or **R/2** position, so change the settings from what is shown on the screen using the **DIRECTION** key and press **ENTER** to save these settings.

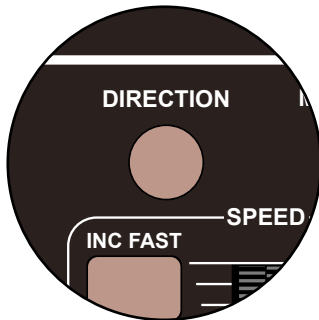

Press

DIRECTION

THEN

Press

ENTER

```
INP:2 L STEP:1
NORM/REV : N/1
```

```
INP:2 L STEP:1
NORM/REV : R/2
```

Step 10

We always finish the command line with an **END** command, then the Super Panel knows it has reached the end of this particular sequence. So press **0** to select **END** and press **ENTER**. Push the **PROG/ESC** key 2 times to return to the **SET INPUT MENU SCREEN**

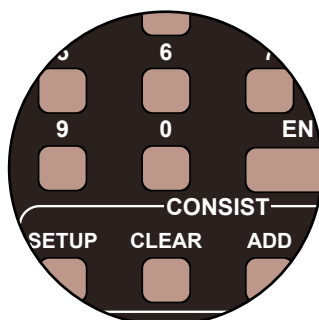

Press

0

THEN

Press

ENTER

```
INP:2 L STEP:2
END: PRESS ENTER
```

```
INP:2 L STEP:3
1=ACCY 2=MACRO >
```

Press **ENTER**. Push the **PROG/ESC** key 2 times to return to the **SET INPUT MENU SCREEN**

Step 11

Now we need to set Route 3 on **Point 2, PM2**, by pushing **3** to start the third command string.

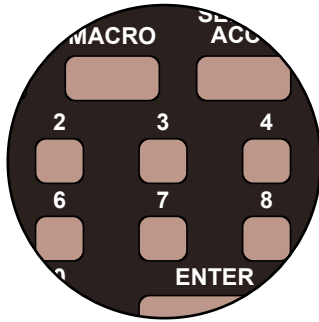

Press

3

THEN

Press

ENTER

```
SETUP INPUT MENU
INPUT:3 LO/HI:L
```

```
INPUT:3 LOW
STEP: 1
```

Step 12

The point motor is an accessory so press **1**, then confirm the accessory number, **31**, as it is still the same point motor as before we need to control, by pressing **3** then **1** and **ENTER**.

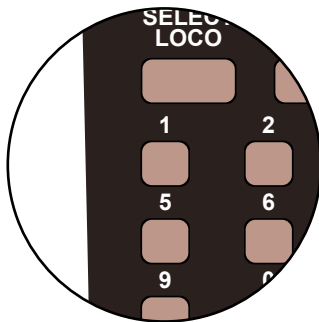

Press

1

Then Press

3

Then Press

1

Then Press

ENTER

```
INP:3 L STEP:1
ACCY NUMBER:31
```

```
INP:3 L STEP:1
NORM/REV : R/2
```

Step 13

We want the motor to move to the **NORMAL** or **N/1** position, so change the settings from what is shown on the screen using the **DIRECTION** key and press **ENTER** to save these settings.

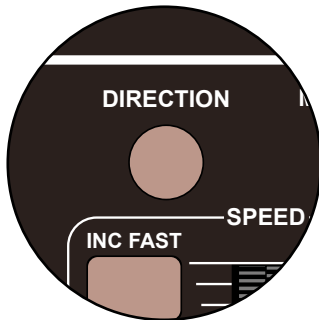

Press

DIRECTION

THEN

Press

ENTER

```
INP:3 L STEP:1
NORM/REV : R/2
```

```
INP:3 L STEP:1
NORM/REV : N/1
```

Step 14

We always finish the command line with an **END** command, then the Super Panel knows it has reached the end of this particular sequence. So press **0** to select **END** and press **ENTER**. Push the **PROG/ESC** key 2 times to return to the **SET INPUT MENU SCREEN**

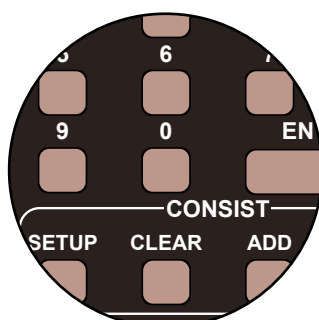

Press

0

THEN

Press

ENTER

```
INP:3 L STEP:2
END: PRESS ENTER
```

```
INP:3 L STEP:3
1=ACCY 2=MACRO >
```

Press **ENTER**. Push the **PROG/ESC** key 2 times to return to the **SET INPUT MENU SCREEN**

Step 15

Finally, we need to set Route 4 on **Point 2, PM2**, by pushing **4** to start the fourth command string.

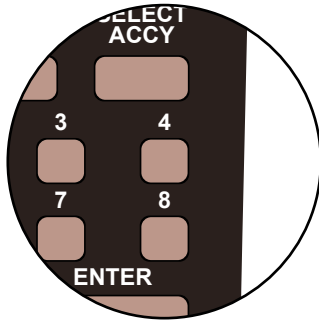

Press

4

THEN

Press

ENTER

```
SETUP INPUT MENU
INPUT:4 LO/HI:L
```

```
INPUT:4 LOW
STEP: 1
```

Step 15

The point motor is an accessory so press **1**, then confirm the accessory number, **31**, as it is still the same point motor as before we need to control, by pressing **3** then **1** and **ENTER**.

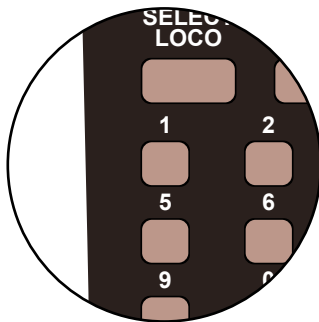

Press

1

Then Press

3

Then Press

1

Then Press

ENTER

```
INP:4 L STEP:1
ACCY NUMBER:31
```

```
INP:4 L STEP:1
NORM/REV : N/1
```

Step 17

We want the motor to move to the **REVERSE** or **R/2** position, so change the settings from what is shown on the screen using the **DIRECTION** key and press **ENTER** to save these settings.

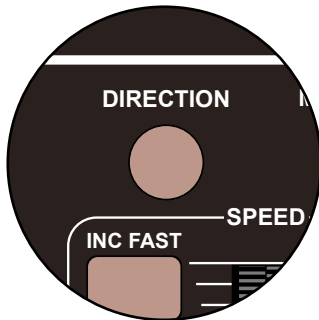

Press

DIRECTION

THEN

Press

ENTER

```
INP:4 L STEP:1
NORM/REV : N/1
```

```
INP:4 L STEP:1
NORM/REV : R/2
```

Step 18

We always finish the command line with an **END** command, then the Super Panel knows it has reached the end of this particular sequence. So press **0** to select **END** and press **ENTER**. Push the **PROG/ESC** key 2 times to return to the **SET INPUT MENU SCREEN**

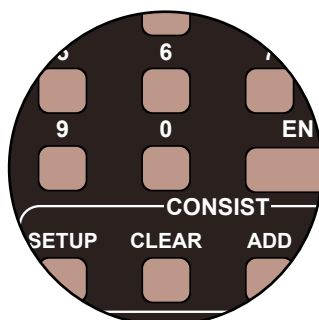

Press

0

THEN

Press

ENTER

```
INP:4 L STEP:2
END: PRESS ENTER
```

```
INP:4 L STEP:3
1=ACCY 2=MACRO >
```

Press **ENTER**. Push the **PROG/ESC** key 2 times to return to the **SET INPUT MENU SCREEN**

Once you become familiar with programming the Super Panel you may find it easier to write out the commands in tabular form so that you can check your logic. This can then be used to input commands to the Super Panel quickly through the NCE keypad - see below for the keystrokes table for **SAMPLE 8**.

Keystroke table for Input 1:

Input No 1			
Select the Input to Input 1		1, 1, ENTER, 1, ENTER	
Step	Keystrokes	LOW Action	HIGH Action
1	1, 30, ENTER, 1, ENTER	Accessory 30 Normal	<i>Not Needed</i>
2	0, ENTER	End	<i>Not Needed</i>

Keystroke table for Input 2:

Input No 2			
Select the Input to Input 2		1, 1, 2, ENTER, 1, ENTER	
Step	Keystrokes	LOW Action	HIGH Action
1	1, 30, ENTER, 2, ENTER	Accessory 30 Reverse	<i>Not Needed</i>
2	0, ENTER	End	<i>Not Needed</i>

Keystroke table for Input 3:

Input No 3			
Select the Input to Input 3		1, 1, 3, ENTER, 1, ENTER	
Step	Keystrokes	LOW Action	HIGH Action
1	1, 31, ENTER, 1, ENTER	Accessory 31 Normal	<i>Not Needed</i>
2	0, ENTER	End	<i>Not Needed</i>

Keystroke table for Input 4:

Input No 4			
Select the Input to Input 4		1, 1, 4, ENTER, 1, ENTER	
Step	Keystrokes	LOW Action	HIGH Action
1	1, 31, ENTER, 2, ENTER	Accessory 31 Reverse	Not Needed
2	0, ENTER	End	Not Needed

Please note: These command streams use the **ENTER** key instead of the **ADD** key as there are no commands in the **HIGH** column, only commands in the **LOW** commands.

See the bottom of Page 39 - 7.1 ACCY - 1 = Accessory Number in the full Super Panel User Guide for more information on this.

Before you can run your program from the SuperPanel you need to reconnect the NCE system to the appropriate input on either the Super Panel or your faceplate. If you have two NCE PowerCab or ProCab handsets you can leave one handset connected to the faceplate or CAB BUS and one to the PROGRAM port at all times, saving you from unplugging an plugging constantly.

PowerCab Run Set Up

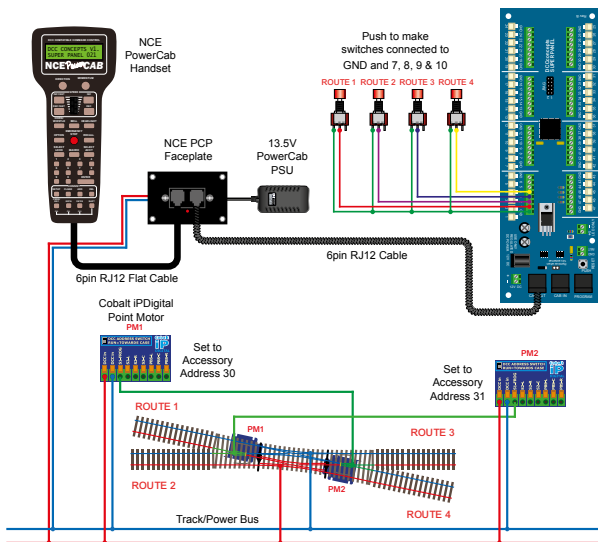

Power Pro Run Set Up

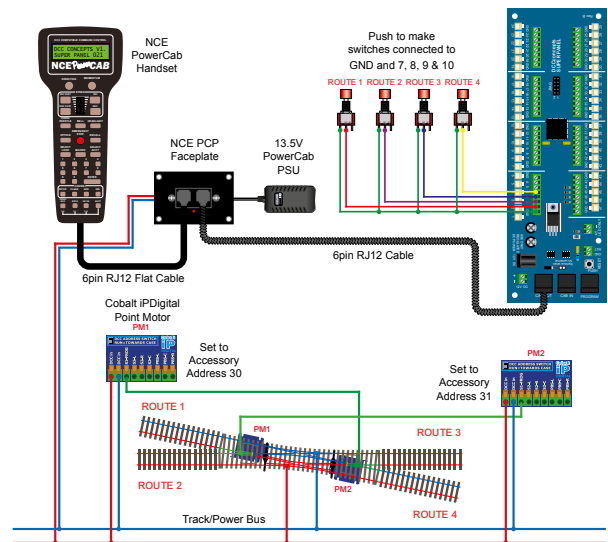

You have now configured your Super Panel to control a double slip using 4 push to make switches.

To control further single or double slips and point motors you just repeat this process, making sure you select the correct input to the Super Panel and the correct digital address for the accessory.

Sample 8 - Layout Concepts Parts List

Qty	Part No.	Description
1 x	DCC-SPL	Super Panel Control Board
1 x	DCD-APB	Alpha Push-Button 6-Pack of Push-Button Switches
2 x	DCP-CB1DiP	Cobalt iP Digital Point Motor Single Pack
2 x	DCD-ACL	RJ12 6pin Curly Cord For NCE Powercab and Cobalt Alpha
1 x	Double Slip	- various makes can be used

Various cable and connectors

Don't forget, you will also need an NCE system, either a PowerCab or PowerPro, to be able to program and run the Super Panel.

Sample 9

Controlling Two Separate Solenoid Points Motors Using Two On-Off Toggle Switches

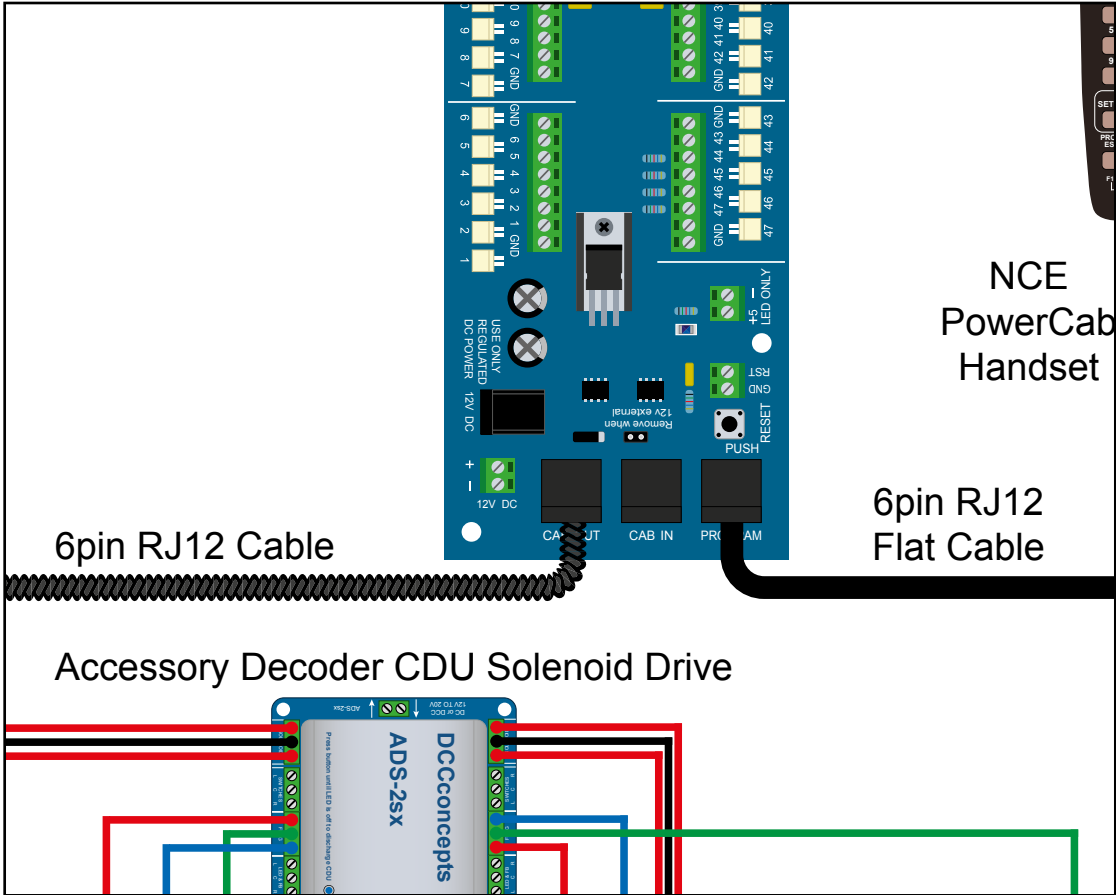

Controlling Two Separate Solenoid Points Motors Using Two On-Off Toggle Switches

Sample 9

PowerCab Programming Set Up

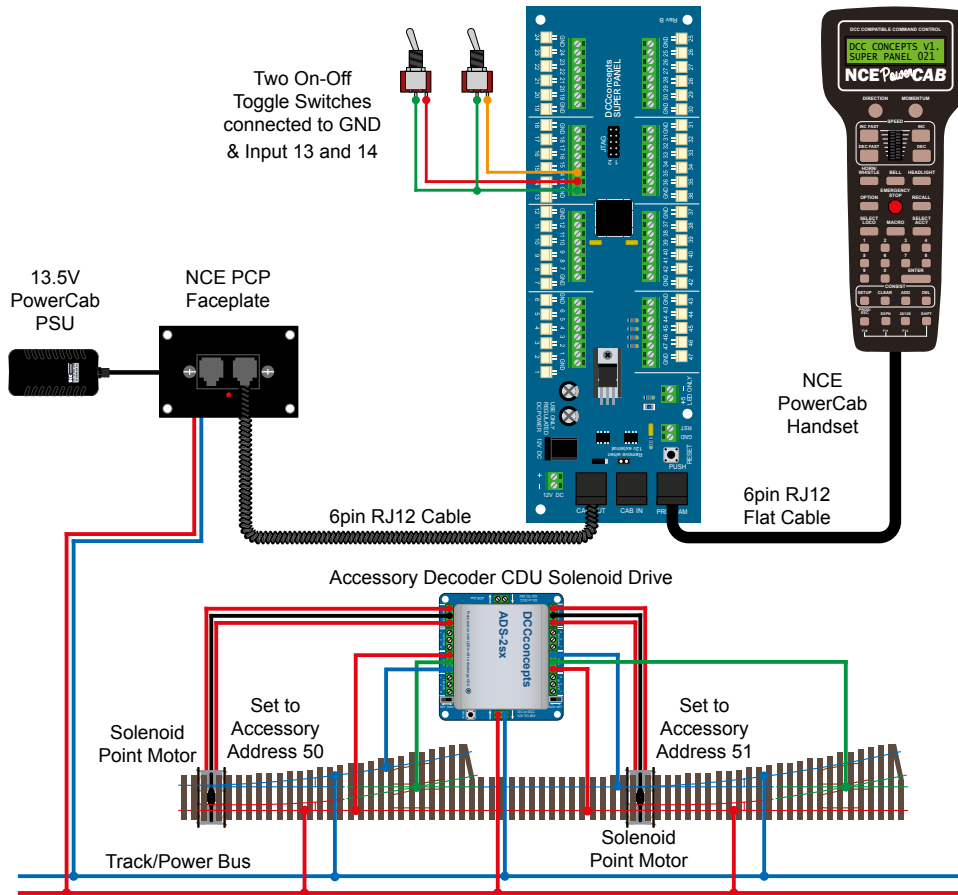

Power Pro Programming Set Up

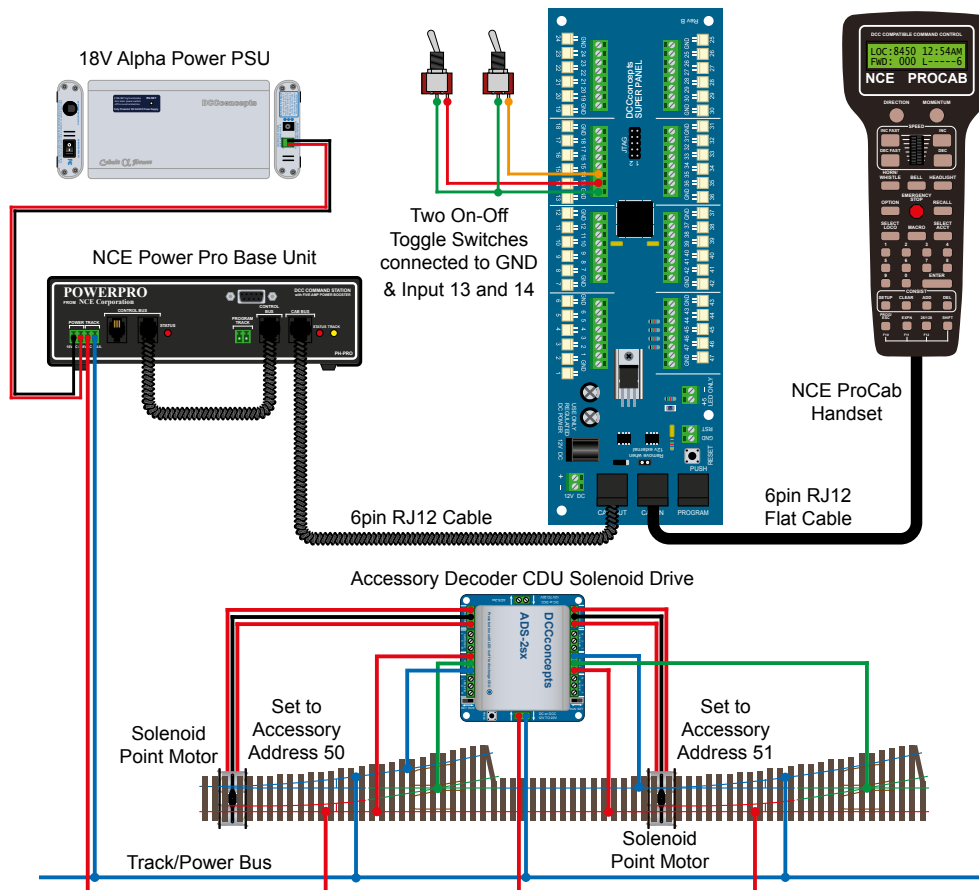

When controlling solenoid point motors, with an appropriate DCC accessory control board, a DCD-ADS-2SX in this case, you have to remember to add a **DELAY** command into your programming structure. This is because the solenoid controller will have a capacitor discharge unit, a CDU, to power the solenoid motor and will need time to recharge after being fired.

In the real world you may accidentally select the wrong switch on your control panel and need to move the same point immediately back to its original position. Without the **DELAY** command in the structure this action may be missed by the decoder unit and the action not completed.

Step 1

Connect everything as per the above diagram and the **START SCREEN** will appear, press **ENTER** to move to the **Main Menu**:

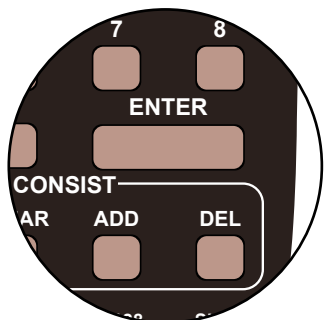

Start Screen

DCC CONCEPTS V1.
SUPER PANEL 025B

Press

ENTER

1=SETUP 2=REVIEW
3=TEST OPERATION

Step 2

Select **1=SETUP** by pressing **1**, and then **1=SET INPUT** by pressing **1**:

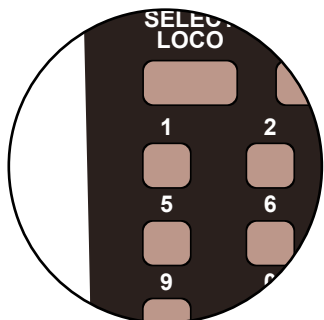

Press

1

THEN

Press

1

1=SETUP INPUT
2=SETUP CONFIG

SETUP INPUT MENU
INPUT:1 LO/HI:L

Step 3

First we set what the switch will do when it is **LOW** or **ON**, so leave the **LO/HI** at **L**. Next select **INPUT:13**, the Super Panel input you have connected the switched terminal from the toggle switch to, by pressing **1** and **3** and **ENTER**, and then select **STEP:1** by pressing **ENTER**:

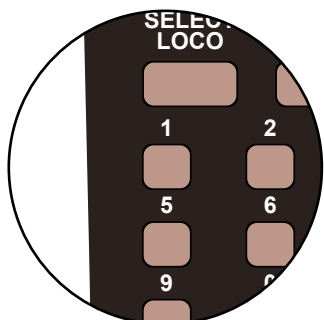

Press

1

THEN

3

THEN

ENTER

THEN

ENTER

SETUP INPUT MENU
INPUT:13 LO/HI:L

INPUT:13 LOW
STEP: 1

Step 4

The point motor is an accessory so press **1**, then confirm the accessory number, **50**, as it is still the same point motor as before we need to control, by pressing **5** then **0** and **ENTER**.

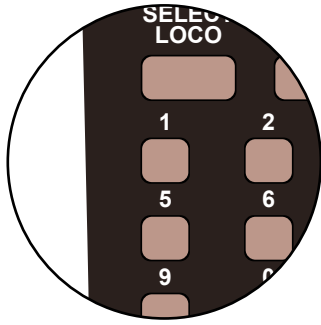

Press

1

Then Press

5

Then Press

0

Then Press

ENTER

```
INP:13 L STEP:1
ACCY NUMBER:50
```

```
INP:13 L STEP:1
NORM/REV : N/1
```

Step 5

We want the motor to move to the **NORMAL** or **N/1** position, so leave the settings as show on the screen and press **ENTER** to save these settings.

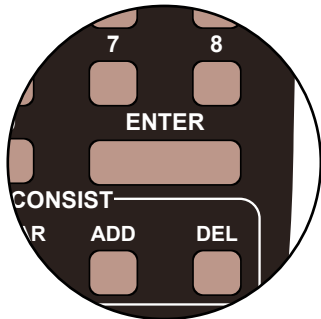

Press

ENTER

```
INP:13 L STEP:1
NORM/REV : N/1
```

```
INP:13 L STEP:2
1=ACCY 2=MACRO >
```

Step 6

Now we need to add the **DELAY** command, which is stored in the **OTHER** sub menu. Press **5** and then **1**

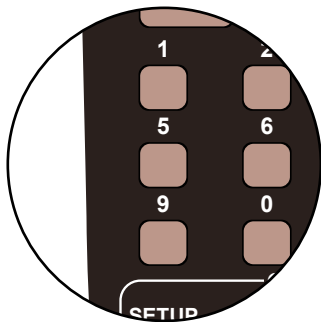

Press

5

Press

1

```
INP:13 L STEP:2
1=DELAY 2=WAIT >
```

```
INP:13 L STEP:2
DELAY QS/4S: Q
```

Step 7

The **DELAY** command is structured in either *multiples of a quarter of a second* or *4 second* blocks. To have a delay of 1 second we need to enter 4 x 1/4 seconds. Leave the screen as it is with the Q showing, press the **INC** and **DEC** keys to toggle between the Q and 4 second screen if needed, and press **ENTER**. Next enter **4** and press **ENTER** to confirm this command.

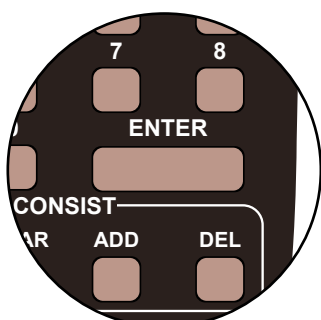

Press

ENTER

Press

4

Press

ENTER

```
INP:13 L STEP:2
Q SEC COUNT: 4
```

```
INP:13 L STEP:3
1=ACCY 2=MACRO >
```

Step 8

We always finish the command line with an **END** command, then the Super Panel knows it has reached the end of this particular sequence. So press **0** to select **END** and press **ENTER**. Push the **PROG/ESC** key 2 times to return to the **SET INPUT MENU SCREEN**

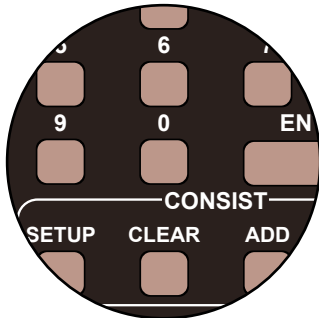

Press

0

THEN

Press

ENTER

```
INP:13 L STEP:3
END: PRESS ENTER
```

```
INP:13 L STEP:4
1=ACCY 2=MACRO >
```

Push the **PROG/ESC** key 1 time to return to the **SET INPUT MENU SCREEN**

Step 9

We now need to set the **HIGH** commands, or what the Super Panel does when the switch is switched **off**. So, press the **DIRECTION** key to select the high commands and press **ENTER**.



Press

DIRECTION

THEN

Press

ENTER

```
INPUT:13 LOW
STEP: 1
```

```
INPUT:13 HIGH
STEP: 1
```

Step 10

The point motor is an accessory so press **1**, then confirm the accessory number, **50**, as it is still the same point motor as before we need to control, by pressing **5** then **0**.

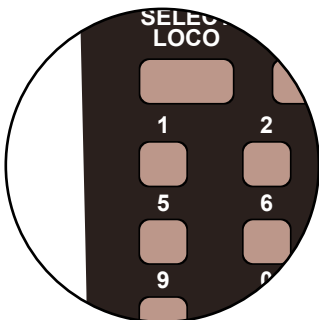

Press

1

Then Press

5

Then Press

0

```
INP:13 H STEP:1
ACCY NUMBER:50
```

```
INP:13 H STEP:1
NORM/REV : N/1
```

Step 11

We want the point motor to travel in the opposite direction, so press the **DIRECTION** key and press **ENTER** to confirm.



Press

DIRECTION

THEN

Press

ENTER

```
INP:13 H STEP:1
NORM/REV : R/2
```

```
INP:13 H STEP:2
1=ACCY 2=MACRO >
```

Step 12

Now we need to add the **DELAY** command, which is stored in the **OTHER** sub menu. Press **5** and then **1**

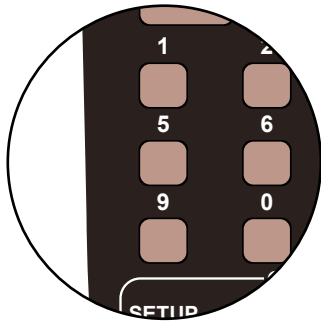

Press
5

```
INP:13 H STEP:2
1=DELAY 2=WAIT >
```

Press
1

```
INP:13 H STEP:2
DELAY QS/4S: Q
```

Step 13

Leave the screen as it is with the Q showing, press the **INC** and **DEC** keys to toggle between the Q and 4 second screen if needed, and press **ENTER**. Next enter **4** and press **ENTER** to confirm this command.

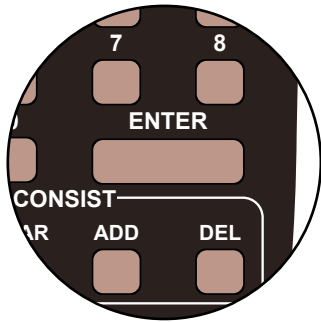

Press
ENTER

```
INP:13 H STEP:2
Q SEC COUNT: 4
```

Press
4

```
INP:13 H STEP:3
1=ACCY 2=MACRO >
```

Press
ENTER

Step 14

We always finish the command line with an **END** command, then the Super Panel knows it has reached the end of this particular sequence. So press **0** to select **END** and press **ENTER**. Push the **PROG/ESC** key 2 times to return to the **SET INPUT MENU SCREEN**

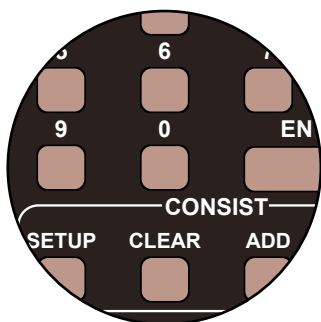

Press
0

```
INP:13 H STEP:3
END: PRESS ENTER
```

THEN
Press
ENTER

```
INP:13 H STEP:4
1=ACCY 2=MACRO >
```

Push the **PROG/ESC** key 2 times to return to the **SET INPUT MENU SCREEN**

To program the second switch, just repeat **STEP 3** to **STEP 14**, replacing the Super Panel input number with **14** and changing the point motor DCC accessory address to **51**, otherwise everything else is the same.

Once you become familiar with programming the Super Panel you may find it easier to write out the commands in tabular form so that you can check your logic. This can then be used to input commands to the Super Panel quickly through the NCE keypad - see below for the keystrokes table for **SAMPLE 9**.

Keystroke table for Input 13:

Input No 13			
Select the Input to Input 13		1, 1, 13, ENTER, 1, ENTER	
Step	Keystrokes	LOW Action	HIGH Action
1	1, 50, ENTER, 1, ADD	Accessory 50 Normal	Accessory 50 Reverse
2	5, 1, ENTER, 4, ADD	1 Second Delay	1 Second Delay
3	0, ADD	End	End

Keystroke table for Input 14:

Input No 14			
Select the Input to Input 14		1, 1, 14, ENTER, 1, ENTER	
Step	Keystrokes	LOW Action	HIGH Action
1	1, 51, ENTER, 1, ADD	Accessory 51 Normal	Accessory 51 Reverse
2	5, 1, ENTER, 4, ADD	1 Second Delay	1 Second Delay
3	0, ADD	End	End

Please note: This command stream use the **ADD** key instead of the **ENTER** key to duplicate the opposite action in the **HIGH** column when entering data in the **LOW** column, or vice versa.

See the bottom of Page 39 - 7.1 ACCY - 1 = Accessory Number in the full Super Panel User Guide for more information on how to achieve this.

Before you can run your program from the SuperPanel you need to reconnect the NCE system to the appropriate input on either the Super Panel or your faceplate. If you have two NCE PowerCab or ProCab handsets you can leave one handset connected to the faceplate or CAB BUS and one to the PROGRAM port at all times, saving you from unplugging an plugging constantly.

PowerCab Run Set Up

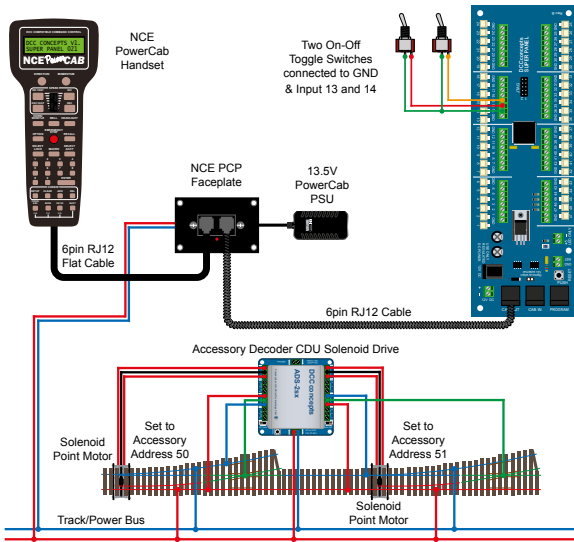

Power Pro Run Set Up

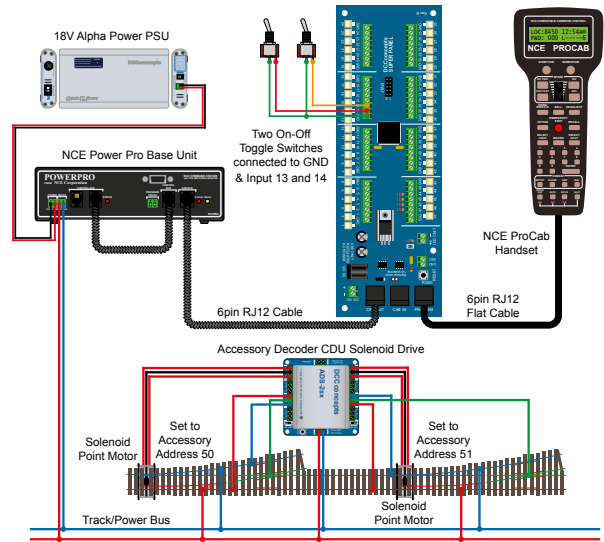

Sample 9 - Layout Concepts Parts List

Qty	Part No.	Description
1 x	DCC-SPL	Super Panel Control Board
1 x	DCD-ATS	Alpha Toggle Switch 6-Pack of On-Off-On Sprung Toggle Switches
1 x	DCD-ADS-2SX	2 Channel Accessory Decoder CDU Solenoid Drive & Digital Relay SX
2 x	DCD-ACL	RJ12 6pin Curly Cord For NCE Powercab
2 x		Left or Right hand points - various makes can be used
2 x		Solenoid point motors - various makes can be used

Various cable and connectors

Don't forget, you will also need an NCE system, either a PowerCab or PowerPro, to be able to program and run the Super Panel.

You have now configured your Super Panel to control two solenoid point motor from 2 Channel Accessory Decoder using 2 toggle switches.

To control further toggle switches and point motors you just repeat this process, making sure you select the correct input to the Super Panel and the correct digital address for the accessory.

LAYOUT

CONCEPTS

**Unit E
The Sidings
Settle
North Yorkshire
United Kingdom
BD24 9RP**

Phone: +44 (0) 1729 821 080

www.layoutconcepts.com

salesuk@layoutconcepts.com