

This is not a toy.
It is unsuitable for
anyone under 14
unless supervised.



ADiA is 100% ESP ready!

General Information



ADiA is 100% ESP ready!



ADiA is 100% ESP ready!

Setting Addresses and Direction



ADiA is 100% ESP ready!



Connections



OWNERS MANUAL

Cobalt

DCD-ADiA

Intelligent 3-address
accessory decoder with
magnetic and IR sensor
connections to use with
DCCconcepts Cobalt iP
Analog and Cobalt Omega



sales@dccconcepts.com www.dccconcepts.com

DCCconcepts ADiA series decoders have some very special features which make them totally unique.

- ADiA fits snugly in the recess in every Cobalt turnout motor (using the pre-fitted foam pad) or mount it separately with the screws we provide.
- ADiA is simple to wire without soldering via screw terminals & plug and play connections (see the wiring diagrams later in this manual).
- ADiA has plug and play connectors ready to accept inputs from DCCconcepts Magnetic or Infra-Red detectors. (see P6 for illustration)
- Each ADiA decoder can be used to drive two Cobalt iP Analog or Omega turnout motors.
- Each ADiA decoder can have three unique addresses, each of which can have its throw direction set to suit a specific route, so it can be used to create route control or set up easy interlocking or similar special circumstances.
- ADiA also has build in switch connections so it can be commanded by any means you choose including DCC control, sensor control and normal switch control, making it super versatile and suitable for use on your layout no matter which way you choose to control it.
- ADiA has a 12 month warranty when used and connected according to our instructions.

GENERAL USE INSTRUCTIONS. (read carefully)

If you prefer to mount ADiA separately, we have provided four screw holes. Use either M3 or M4 screws. Please take care and do not over-tighten.

Connections: Please use correctly sized wires. We recommend 1mm² wire which will be suitable for all connections on ADiA and Cobalt motors.

Infra-Red and Magnetic sensors are plug and play. Please see the connection diagrams in this manual.

DCC Power Input: ADiA should connect directly to the DCC Track Power Bus. You can of course use a separate Accessory Bus, however current draw of both ADiA and Cobalt analog motors is very low making a separate bus largely unnecessary.

DCC voltage levels: ADiA accepts all standard DCC power bus voltages, but for best results use 12V~18V DCC as our recommended limits.

Using the Address Setting Switches: There are 3 small switches which can be independently set. The switch positions are "Set" and "Run".

We very strongly recommend careful use of either a plastic or wooden toothpick to move the switch between its set and run positions.

Please do NOT use a sharp screwdriver to move the switch or the switch tab may be cut. Switch damage will not be covered by warranty.

Setting the ADiA's three independent addresses.

Using only ONE address? You may sometimes only need to use one address. If so, so that there is no later conflict, set addresses two and three to an address above the range you will use for other accessories. (ADiA's default addresses are 1, 10,100) (example, if you are using say 1 ~ 100 for turnouts, set them to any address you wish to use above 100)

How to set an ADiA address:

- Decide the number you want to use (1~2044)
- If not already installed, connect that ADiA to the MAIN power bus and turn on your DCC system.
- Using a toothpick or similar, move the relevant tab on the DIP switch to the SET position.
- Now, follow your DCC controller's instructions for changing a turnout using the address that you wish the ADiA to respond to. *(Repeat this twice. i.e change left and then to change right.*
- Return the switch to the RUN position.
- Your ADiA will now respond to that address.
- If needed, repeat the above instructions for each of the 3 available independent addresses.

Important:

- Do NOT try to set more than 1 address at a time.
- All Switches must be set to RUN to operate ADiA.

Setting the "Throw" direction for each address.

It is convenient to swap throw direction by command rather than needing to swap wires, and it is essential when using the 3 addresses to set routes or interlock special pointwork such as 3-ways and slips.

How to change throw direction for each address.

- Decide which address needs to change direction.
- If not already installed, connect that ADiA to the MAIN power bus and turn your DCC system on.
- Using a toothpick or similar, move the relevant tab on the DIP Switch to the SET position.
- Now, using your DCC Controller, go to "Program on the main". (On ECoS and Z21, use the Loco Program on main screen)
- If prompted for an address, use the address for the motor you are setting OR any address not used in locos or other accessories on the layout.
- In the Set CV screen, choose CV57 for address #1, CV58 for address #2 or CV59 for address #3.
- Set the CV to 0 for normal, or to 1 for reverse.

How to change IR reaction speed and sensitivity. (Motor movement start after Sensor is triggered).

- As above, but use CV 60. The range is 1ms to 255ms, and the ex-factory default setting is 20

How to restore your ADiA to ex-factory settings.

- As above, then set CV63 to a value of 36.

DCCconcepts ADiA Accessory Decoder has been created to work perfectly with Cobalt iP Analog, Cobalt Omega or similar types of turnout motors.

As you can see, ADiA fits perfectly into the recess in the sides of Cobalt iP Analog or Omega motors.

ADiA is easy to connect.

with screw terminals and direct plug connection for DCCconcepts magnetic & infra-red sensors so you can have motors automatically move to align, preventing any accidental derailments.

ADiA is very, very clever.

With 3 addresses in each ADiA, you can set routes or operational conditions to make 3-way turnouts or special trackwork work the way you want it to.

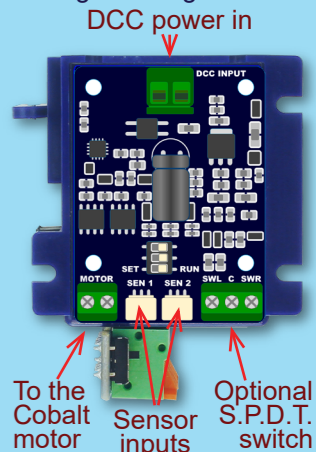

Designed & Created by

DCCconcepts Ltd

Unit E, The Sidings. Settle North Yorkshire BD24 9RP
Ph: +44 (0) 1729 821 080
sales@dccconcepts.com
www.dccconcepts.com

barcode



ADiA is 100% ESP ready!

Using all 3 addresses and the "direction change option" for route setting or special pointwork:

Here's a scissors crossing to interlock the crossovers and have 4 button control too using ADiA decoders.

Connect to ADiA #1 Settings for ADiA #1 Addr 1. CV57=0. Addr 2. CV58=1

Settings for ADiA #2 Addr 1. CV57=0. Addr 2. CV58=0

Connect to ADiA #2

Connect to ADiA #1

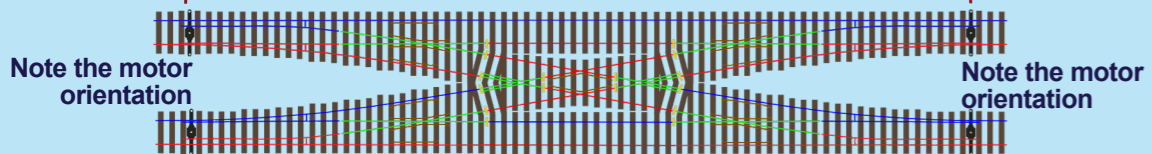

Connect to ADiA #2 Full wiring & logic diagram available on our website! "Scissors with ADiA interlocking"

Connect to ADiA #1

You can also use the added addresses and "direction change option" for most special pointwork:

Here's another simple example using the ADiA's abilities to give easy 3-button control of any 3-way turnout.

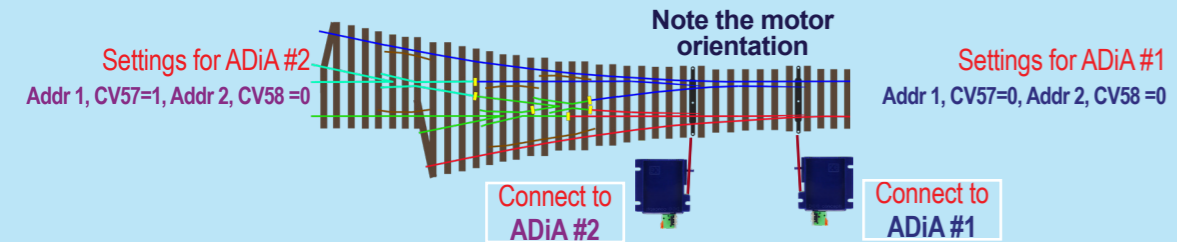

Settings for ADiA #2 Addr 1, CV57=1, Addr 2, CV58=0

Settings for ADiA #1 Addr 1, CV57=0, Addr 2, CV58=0

Connect to ADiA #2

Connect to ADiA #1

Full wiring & logic diagram available on our website!
"3-way with ADiA interlocking"



ADiA is 100% ESP ready!



ADiA is 100% ESP ready!

A reversing loop using sensors

ADiA is 100% ESP ready!

Automating a reversing loop or pre-aligning the turnout ready for an approaching train:

Let's automate a reversing loop... or make a turnout change to prevent accidents from wrong settings! The only real difference is where the sensors are positioned. This approach works equally well with either infra-red or magnetic sensors and with ADiA, it is much easier to wire than you might imagine.

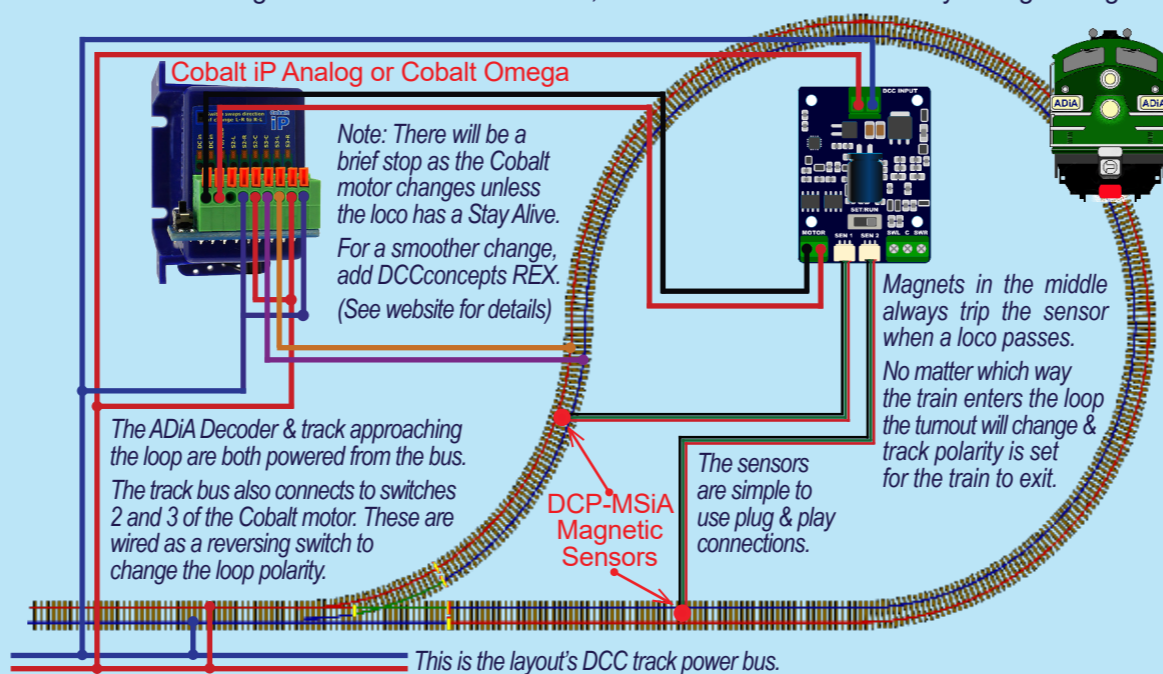

ADiA is 100% ESP ready!

Turnout control using sensors

ADiA is 100% ESP ready!

Automation to set routes or to safely align turnouts ready for an approaching train:

Let's have some sensible fun. Freight trains to the slow line, passenger trains to the express route! We'll use magnetic sensors for this one, because they let us define locomotive types via positioning.

We can ALSO make sure that the turnout is set correctly by adding another magnet on the centre-line of each loco, so derailments as the train moves over turnouts from left to right are gone forever!

Look at the coloured positions under the loco's & match to the coloured DOTS (sensors) on the track. Remember that the turnout motor may need time to change, so space the magnets to give them time!

