

Overview: Cobalt REX

The ultimate add-on item for switching and Control
When we create anything, we do our best to make sure that it is equally usable by DC or DCC modellers. We also always do our best to include as many useful features as we can.

We try for versatility too, making things like Cobalt motors with more than one on-board SPDT switch - able to be changed with DCC, with Push-button control as well as designing them to be triggered by things such as detectors, hall triggers and reeds etc because we know prototypical interlocking is complex and modellers love to be creative. Inevitably though, there are some situations that still just need more...



That's why "There is no point doing things by halves" is a core design philosophy that we love to work, and REX is a product that fits into that thought process very well indeed!

A small but clever switching board. REX is fitted with FOUR high power relays that can be switched any way that you want and they can then be configured to achieve any possible result we can think of! Welcome to the Cobalt REX. Now you can do anything you want!

Overview: Cobalt REX features

- Rex will work on 12-18v DC or can connect to DCC track power
- Rex has 4 built-in SPDT changeover switches (relays).
- Rex can change all its contacts at once, or it can become two independent switching devices just by moving a switch.
- Rex can be controlled by N.C. (on-on) switches or N.O. (normally off) switches - in fact you can operate each half separately and either way - again just by changing a switch!
- Rex has power-off memory so it remembers its settings
- Rex is easy to use and wire into your layout as every terminal is labelled clearly.
- Rex is easy to configure. There are 3 clearly marked slide switches giving you easy access to all of the options.

A look "Under the cover" of Cobalt REX (a detailed chart can be found overleaf)

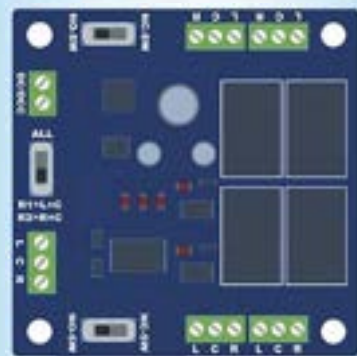

More information about the many possible Cobalt REX connections and how they can be used

Cobalt REX inputs:

Power input can be DC or DCC: This is nominally 12-18v. As with all digital devices, if you use DC power, please use a "regulated DC power supply" for best results. Cobalt REX current draw is low so a wall plug or similar is fine. (Rex needs less than 100mA).

Control input terminals L-C-R. Connection of switching devices:

If using switches for changes - They can be either one N.C. type SPDT On-On switch attached to L, C, R or you could use two N.O. type push-button, TACT or Reed switches attached to L+C & C+R.

If using Detectors for changes - They should be 3v to 5v output as used for normal detector feedback and if so, they can be connected directly. Before connection please measure the output and add a resistor into one wire if they are any higher in voltage or damage will result. Over-Voltage damage will NOT be covered by warranty
Using any Cobalt Product for switching - You can connect Cobalt REX to the SPDT switches on any other Cobalt product, and it can also be wired in parallel with any switch that also operates another cobalt product (Do NOT connect REX to point motor outputs of an AD-Fx or AD-Six type decoder as they are much too high in voltage.)

Power-off Memory: Cobalt REX has full power-off memory. It can remember its "last position setting" for when you turn the power off and then on again... so you can take up where you left off.

Cobalt REX is neither a DC nor DCC device - it is equally happy being powered by DC or DCC and it can control both DC and DCC devices.

However you should be aware that when long runs are involved both the quality and size of the wires used matters as higher inductance and resistance will increase voltage drop. This affects DC and DCC devices!

Similarly the quality of your power supply really matters. Please use only regulated DC power supplies & DCC voltages within specification to ensure best results and long life. Avoid train-set power supplies!

Using the Upper and Lower "Switch type" selectors:

There are marked NC-SW and NO-SW. Each controls the two switches alongside it on that side of Cobalt REX.

LEFT position: (NO-SW on the PCB) - In this position, you can use push-buttons, reeds, Hall triggers, TACT switches or any other form of momentary switch... even stud and probe if you want!

RIGHT position: (NC-SW on the PCB) - In this position, use SPDT switches and similar on-on devices. You can also use this position if you connect REX to the auxiliary SPDT switches on a Cobalt turnout motor / accessory decoder etc.

Connecting things to the 4 relays: Each relay is independent of the Cobalt REX circuitry and there are NO electrical links either relay-to-relay or relay-to-Cobalt REX. Because of this you can easily connect anything at all, any way you want... OR link them safely.

Examples: You can link two contact sets together - An example is linking any two sets as a double-pole, double-throw switch- this lets REX act as an auto reverse device or to change an Omega or iP Analog Cobalt Motor or similar device automatically.

Linking any two switches in series, creates an interlocking or what is known as a "conditional situation" where both sets of contacts will then need to change to let something happen...

Installing or mounting Cobalt REX around the layout:

Cobalt REX has a busy PCB with lots going on, but we still found room for holes that will work with 3mm (1/8") mounting screws.

All you need to do is to choose where it will go. Alternately, double sided foam tape on the bottom surface of REX will hold it in place.

(Cobalt REX is designed with a component-free underside. This makes mounting very easy as it is already rubber protected too).

More information about switches and outputs for Cobalt REX and how they can be set up and used

THIS is Cobalt REX, close to full size. "As it is Under the Cover".

Enjoy using Cobalt REX, and as long as you have read these instructions, and work carefully, don't be afraid to be creative & experiment!

The RELAYS are the OUTPUTS of REX

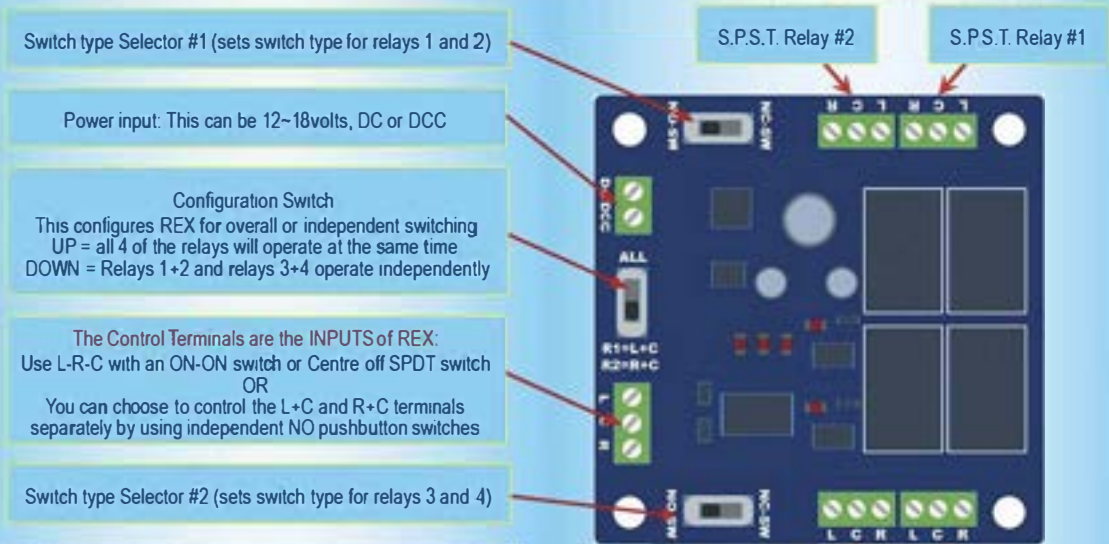

Need help or advice? Email us at: Questions@dccconcepts.com
Or to find out more, visit our website: www.dccconcepts.com
DCCconcepts Ltd - UK & Australia

Part number DCP-REX

9 347394 001246

Overview: Cobalt REX Switch types

Rex can be used with several switch types as it's sometimes useful to have more than one form of switching. For example, you may want to switch something manually, but also want a passing train to activate it or make things happen automatically

You CAN do this because it's OK to wire two N.O. (normally-off) devices such as detectors and push-button switches in parallel onto each control position at the same time. (ie to L+C or C+R)

Add the versatility of switch choice to total connection flexibility, and with Cobalt REX, you can do anything that you can imagine!

AN EXPLANATION OF THE SWITCH TERMS USED

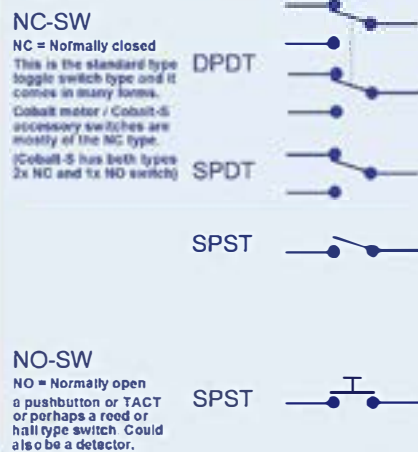

The DCCconcepts Cobalt Collection - Innovative design and a creative approach to almost "Wire free" layout control.

Alpha-Mimic

At last - Realistic Signal box or control panel diagrams without the need for any complex wiring and with NO cutting of wires or soldering required as Alpha Mimic is totally plug-and-play! Alpha-Mimic panels and LEDs simply plug together so an illuminated Mimic Panel is now as easy to assemble as Lego™.

Alpha-Mimic works with ALL DCC system brands. This also makes it a perfect match for Cobalt Alpha, Alpha Central, Alpha-Switch-D and Cobalt-S Levers of course.

Alpha Mimic is totally self-sufficient and simply connects to the track power bus, needing only two wires and NO other wiring.

Each Alpha Mimic provides plug-and-play links for 24 LED outputs (each capable of managing several Mimic LEDs) that will reflect the status of DCC controlled accessories on your layout panel. Of course, multiple Alpha-Mimic boards can be linked for complicated layouts, displaying the status of over 2000 DCC Accessories - Yet addressing the Alpha Mimic outputs remains VERY simple to do.

Our exclusive "Alpha-LED" design, has been created for easy installation.

With one output able to control several LEDs a well designed control panel can also define routes clearly and show the route selected! Alpha-Mimic is available with Red, Green or Red + Green 2-colour LEDs. (We also offer matching add-on Alpha-Mimic LED packs which include extension leads and multiple-link adapters).

We have even created a file of Railway track-diagram symbols and icons to help you with your control panel design (Available On our Website or by email from Questions@DCCconcepts.com).

Cobalt Alpha



This is the very Heart of Alpha products. Cobalt Alpha interprets commands from ANY momentary switch, giving it a digital output. Cobalt Alpha lets you to connect ANY form of switch, from "Stud and Probe" to a simple push-button.

Cobalt Alpha is also ideally suited for Cobalt-S Levers and the sophisticated, "Easy-to-connect" Alpha-Switch-D. No matter which switch you choose, wiring is greatly reduced as Cobalt Alpha Digitises all switch commands. So... all wiring is within the Control Panel. Most will be plug and play with NO soldering needed too!

And - because of Alpha's clever approach to control, your ENTIRE Control panel, no matter how complex, needs just ONE cable to connect it to the layout.

There's more to come from Alpha Mimic too!
Very soon, Mimic will also be packed with 12 ready-to-go, highly accurate, DCC controlled ground signals in FOUR different styles for UK, US and Australian modellers.
With connection a simple plug-and-play and the cost per signal is compatible with low cost plastic kits, Alpha Mimic signals will be unbelievably economical & easy to install!